

Industrial Electrolytic Conductivity Cells for UDA2182 Series and APT Series

Specification

Main Overview

The specification of an Electrolytic Conductivity Cell requires careful consideration of the following factors:

1. Appropriate Cell Constant, determined by the analyzer or recorder used. See instrument range table.
2. Chemical resistance.
3. Physical nature of mounting; insertion, immersion, flow through, insertion/removal and laboratory type.
4. Temperature/pressure rating required.
5. Integral automatic temperature compensator. Determined by the analyzer or recorder used.

Appropriate Cell Constant - Reference Information

The choice of cell constant is determined by the measuring instrument and its range.

Cell constant - The cell constant describes the cell's geometry. It is the length between electrodes divided by the effective sample area between them. The standard 1 cm^{-1} constant cell can be visualized as 2 plates of 1 cm^2 area spaced 1 cm apart. Other cell constants have different length/area ratios.

Applying the cell constant to the measured resistance/conductance converts it to resistivity/conductivity - a property of the fluid independent of the measuring apparatus and sample size.

Proper cell constant - A variety of cell constants is needed to measure the complete range of electrolytic solutions from less than 1.0 ohms-cm to greater than 18 megohms-cm.

For accuracy, the measured resistance must be at a level that will give the best sensitivity for the measuring circuit. At very low measured resistance, polarization effects and leadwire resistance could affect accuracy. This is avoided by choosing a cell constant which will raise the measured resistance to an acceptable level. At very high resistance values, leadwire capacitance can affect the accuracy. This is avoided by selecting a cell that will lower the measured resistance to an acceptable level.

To measure high purity water, a low cell constant is specified which lowers the measured resistance. Conversely, sulfuric acid may have a specific resistance of 1.0 ohm-cm; therefore, a 50 constant cell should be used to raise the measured resistance to 50 ohms.

Selection Guide for Conductivity Cells and Compensators

4973 Type Should be quoted whenever possible for constants 0.01 to 10 cm^{-1} .

When measuring deionized water where the cell has the potential of being exposed to regeneration acids and bases, the 4973 Cell with its titanium electrodes and rapid temperature response are preferred.

If a 4905 cell is used, the platinum electrodes are best, but the nickel (except for Monel electrodes for the 0.1 constant) electrodes are suitable and should be bid in a competitive situation.

4905 Type Widest choice of cell constant - should be quoted on all applications where 4973 is not applicable and for replacements.

4909 Type Should be quoted when cell removal is required without disturbing the process.

Physical Nature of Mounting

Proper mounting of a cell is as important as any other parameter. A cell improperly installed may not give an accurate indication of the true process conditions. Careful consideration should be given to the mounting.

Insertion Cell can be mounted directly in process stream. Location should be in rapid fluid motion and in a position that will prevent sediment accumulation. Also suitable for lab use.

Immersion Cell can be mounted over a tank or open trough. The cell should be completely immersed to avoid a false indication of high resistivity (low conductivity) or incomplete temperature compensator immersion.

Flow Cell assembly can be placed directly in process fluid line or bypass sample line. The cell should be completely immersed and positioned to prevent accumulation of sediment to avoid false indication of high resistivity (low conductivity).

Insertion/Removal cell can be removed at pressures 50 psi or less without disturbing the process.

4973 and 4974 Type Overview

These cells are ruggedly constructed for reliable, continuous measurement of electrolytic conductivity in industrial water processes at temperatures up to 140°C and pressures up to 250 psig.

The cells feature polyethersulfone (PES) construction for high-corrosion resistance, with electrodes of titanium (for 0.01 and 0.1 cell constants) and high-density graphite (for 1.0 and 10.0 cell constants).

For *insertion* applications, the 3/4" NPT male thread permits permanent installation in a pipe or tank; the cell can also be used as a laboratory dip-type for batch sampling.

For *flow* applications, the cell can be installed directly into a process stream, or used with a separately ordered 3/4" pipe tee in a by-pass stream. The cells have been designed to keep the electrodes and the temperature compensator immersed in the stream flow, ensuring that the cell will respond quickly and accurately to changes in both solution concentration and temperature.

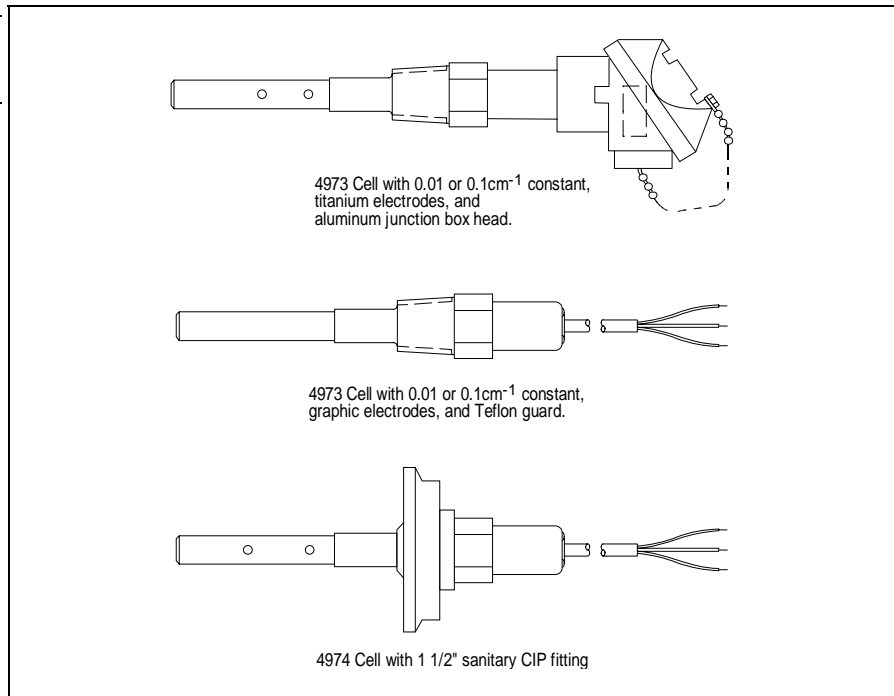

For *sanitary clean-in-place (CIP)* piping systems, the 4974 cells include standard 1 1/2" or 2" CIP fittings suitable for food and beverage, pharmaceutical and cosmetic, or biotechnology industries. There is no equivalent DL4000 Series for the style of cell.

Connections

Integral cable: The 4973 and 4974 cells offer this option that provides a cell with a potted cable. The cable and cell are one entity and cannot be separated. This configuration can be used in all applications.

Quick disconnect cable: Only the 4973 offers this option that provides a cell with a potted Turck receptacle. The cable mates with this receptacle. The cell and cable are separate entities. This configuration cannot be used in immersion applications. Mating cable must be purchased from Honeywell.

Specifications	
4973/4974 Type (DL43XX for DirectLine® Module)	
Automatic Temperature Compensator	Supplied on all cells
Cell Constant	4973/4974: 0.01, 0.1, 1.0, and 10 cm ⁻¹
Maximum Temperature Limit	4973: 140°C (284°F) at rated pressure 4974: 130°C (266°F) at rated pressure, may be further limited by CIP gasket and clamp type
Maximum Pressure Limit	4973: 1724 kPa (250 psig) at rated temperature 4974: 1034 kPa (150 psig) at rated temperature, may be further limited by gasket and clamp type
Insertion	4973 cells: 3/4" NPT male thread for schedule 40 and 80 pipe 4974 cells: 1 1/2" or 2" sanitary CIP fitting

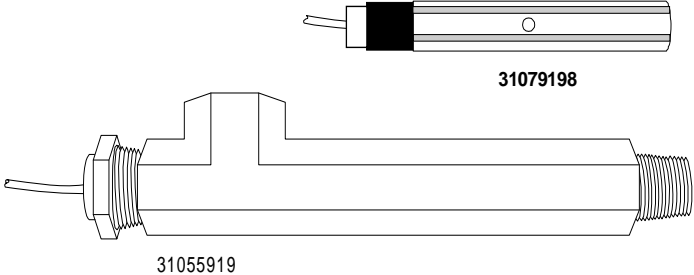
Specifications	
4973/4974 Type (DL43XX for DirectLine® Module)	
Insertion Depth	89 mm (3 1/2") for 1, 10, and 0.01 constants from solution end of 3/4" NPT male thread 64 mm (2 1/2") for 0.1 constant
Wetted Parts	Cell body: PES (polyethersulfone) Electrodes: 0.01 and 0.1 constant, titanium; 1.0 and 10.0 constant, high-density graphite with Teflon guard. 4974 series also includes food grade silicone rubber and polished 316 S.S.
Lead wire	4973/4974: Integral PVC-covered, non-shielded, 18-gage cable. If more than 50' is required, specify the junction box head and the required length of extension cable (head has 1/2" NPT conduit connection). For a separate junction box, specify part number 31316260, and appropriate length of cable.
Electrical Connections	4973: Integral cable – 4 leads with integral Automatic Temperature Compensator Quick disconnect option – Turck mating head with cable must be purchased from Honeywell. This option cannot be used in immersion applications. 4974: Integral cable – 4 leads with integral Automatic Temperature Compensator
Weight	4973: 0.2 kg (0.5 lb.) 4974: 0.4 kg (1 lb.)
Approvals	4973: Manufactured to comply with ASME boiler and pressure vessel code Section VIII, Div. 1, UG-101. CRN #0F11607-5C
<p>Flow Chambers for 4973</p>  <p style="text-align: center;">31079198</p> <p style="text-align: center;">31055919</p> <p>Flow Chambers (ordered separately) used with 4973 Cell for Sample Stream Measurements</p>	
055919	Max. Flow: 5 gpm at 40 psig Material: PES Max. Pressure: 200 psig at 25°C Max. Temperature: 140°C at 5 psig Dimensions: 38 mm x 222 mm (1 1/2" x 8 1/4") Sample Inlet: 3/4" NPTM Sample Outlet: 3/4" NPTF Cell Port: 3/4" NPTF
31079198	Max. Flow: 750 cc/min. Material: 316 stainless steel Max. Pressure: 200 psig (1378 kPa) Max. Temperature: 140°C Dimensions: 38 mm (1 1/2") dia. X 114 mm (4 1/2") Sample Inlet: 1/8" NPTF Sample Outlet: 1/8" NPTF Cell Port: 3/4" NPTF

4905 Type Cells Overview

Constructed of PES for high corrosion resistance, 4905 Series cells can be supplied with either nickel or platinum electrodes, and will provide continuous reliable measurements at temperatures up to 140°C at pressures up to 250 psi.

For insertion applications, the 1" NPT male thread permits installation in a pipe or tank, for flow applications, the cell can be installed directly into a process stream, or used with a separately ordered 276127 Flow Chamber in a bypass stream.

For immersion applications, ½" rigid or flexible plastic pipe can be threaded into the top of the cell: up to 19' (5.8m) for the 20' cable; up to 49' for the 50' cable. When used in immersion applications, temperature must not exceed 85°C.

Connections

Integral cable: The 4905 cell offer this options that provides a cell with a potted cable. The cable and cell are one entity and cannot be separated. This configuration can be used in all applications.

Quick disconnect cable: The 4905 also offers this option that provides a cell with a potted Turck receptacle. The cable mates with this receptacle and must be purchased from Honeywell. The cell and cable are separate entities. This configuration cannot be used in immersion applications.

Specifications

4905 Series Cell (DL45XX for DirectLine® Module)	
For high corrosion resistance, the 4905-Series Cells can be supplied with either nickel, platinum, or monel electrodes.	
Application	
Insertion	The 1" NPT male thread permits installation in a pipe or tank; the cell can also be used as a laboratory dip-type for batch sampling.
Immersion	1/2" rigid or flexible plastic pipe can be threaded into the female thread on the top of the cell. Temperatures must not exceed 85°C. Up to 5.8 m (19') for the 20' cable, up to 49' for the 50' cable..
Flow	The cell can be installed directly into a process stream, or used with a separately ordered 276127 Flow Chamber in a bypass stream.
Flow Velocity	Maximum 10 ft./sec (3.0 m/sec)
Specifications	
Approvals	Manufactured to comply with ASME boiler and pressure vessel code Section VIII, Div. 1, UG-101. CRN #0F11607-5C
Cell Constants	4905 Model: 0.01, 0.1, 1.0, 10, and 50 cm ⁻¹
Electrode Material	Nickel, Monel or platinum, as specified. Constants 10 and higher are platinized.
Leadwire	4905: Tefzel-covered 18-gage cable 20' or 50' long, as specified. If more than 50' is required, select either the cast aluminum junction box head option or select the 50' option and the separate 31316260 cast iron junction box and additional length of leadwire as necessary.
Electrical Connections	4 or 6 leads with integral Automatic Temperature Compensator. Integral cable – 4 leads with integral Automatic Temperature Compensator Quick disconnect option – Turck mating head with cable must be purchased from Honeywell. This option cannot be used in immersion applications.
Pressure	250 psig @ 140°C (284°F) maximum
Temperature	140°C (284°F) maximum continuous (the temperature limit for the A.T.C. accuracy may be lower than the cell's material-of-construction temp. limit).
Mounting	1" NPT male
Insertion Depth	114 mm to 175 mm (4.5" to 6.9") depending on cell constant; 112 mm or 224 mm (4.4" or 8.8") additional depth available on special order.
Wetted Materials	Cell: polyethersulfone Electrodes: Nickel, Platinum, or Monel (as specified)
Weight	Approximately 0.45 kg (1 lb.)

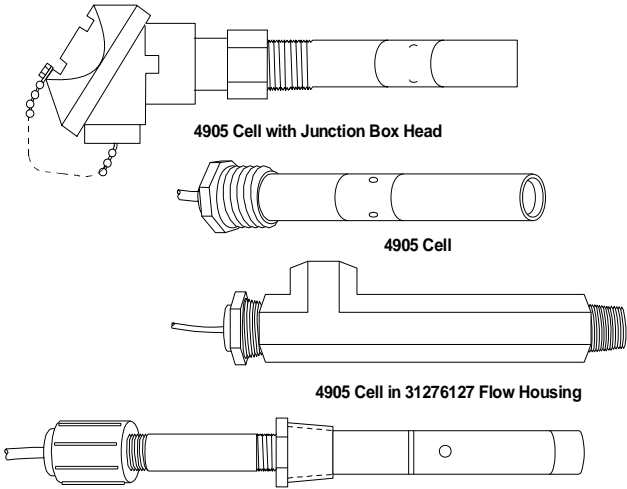
Specifications	
 <p style="text-align: center;">4905 Cell with Junction Box Head</p> <p style="text-align: center;">4905 Cell</p> <p style="text-align: center;">4905 Cell in 31276127 Flow Housing</p> <p style="text-align: center;">4905 Cell for Immersion, with Plastic Extension Pipe (Supplied by User)</p>	
276127 Flow Chamber	
Pressure	200 psig maximum @ 25°C (77°F)
Temperature	140°C (284°F) maximum @ atmospheric pressure
Flow	2 gpm @ 40 psig and atmospheric discharge
Dimensions	38 mm (1 ½") octagon x 222mm (8 ¾") long Sample Inlet: ¼" NPTM Sample Outlet: ¼" NPTF Cell Port: 1.0" NPTF

4909 Type Cells Overview

4909 Cell Assemblies, available in 316 Stainless Steel or CPVC Plastic, allow insertion or removal of the cell without interruption to the process.

Two safety features, a restraining mechanism and an internal safety stop, provide protection to an operator for safe cell removal at pressures up to 50 psig with caution.

The plastic removal device is equipped with a purge port to flush out any accumulated debris to aid in easy insertion or removal of the cell. The replacement cell for a 4909 assembly is a 4908 (DL4-8xx)

4909 Series Cell	
Specifications	
Cell Constants	0.01, 0.1, 1.0, 10, and 50 cm ⁻¹
Electrode Material	Nickel, Monel or platinum, as specified. Constants 10 and higher are platinized.
Flow Velocity	Maximum 5 ft./sec (1.5 m/sec)
Leadwire	4909: Tefzel-covered 18-gage cable 20' long, as specified. If more than 20' is required, use universal head cast aluminum (½" NPT) junction box and appropriate length of cable. Universal heads are cast aluminum with ½" NPT, female conduit connection and terminals to accommodate cell and automatic temperature compensator connection. DL49XX: PC board connector for mounting DirectLine® Module integrally on cell, 20' integral cell cable for mounting DirectLine® Module remotely.
Electrical Connections	4 or 6 leads with integral Automatic Temperature Compensator and EEPROM (DL4000).

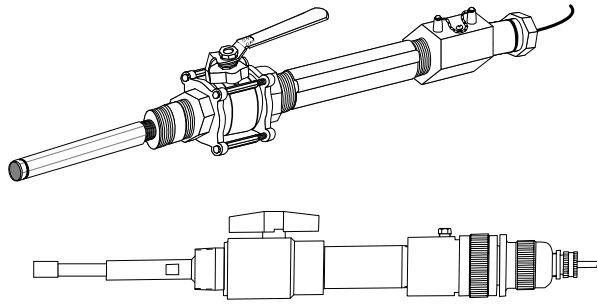

Top: 4909 SS Insertion/Removal Cell Assembly
Bottom: 4909 CPVC Plastic Insertion/Removal Cell Assembly

Specifications for 4909 316 SS Assembly

Approvals	Manufactured to comply with ASME boiler and pressure vessel code Section VIII, Div. 1, UG-101. CRN #0F11607-5C
Pressure	1379 kPa (200 psig) maximum at 140°C (284°F). Maximum pressure for removal or insertion is 50 psig. For CRN approval: 80psig @ 140°C (284°F)
Temperature	140°C (284°F) at 200 psig
Process Connection	1 1/4" NPT male
Insertion Depth	Varies between 165 mm and 224 mm (6.5" and 8.8") from end of nipple, depending on cell constant.
Overall Length	From process connection: 422 mm (16.6"); 521 mm (20.5") with junction head option
Total Length Required for Cell Removal	1130 mm (44.5"); 1238 mm (50.5") with junction head option.
Wetted Materials	316 SS ball valve; Viton & Teflon internal sealing materials; PES cell; nickel, platinum, or monel electrodes, as specified.
Weight	4.5kg (10 lbs.)

Specifications for 4909 CPVC Plastic Assembly

Pressure and Temperature	862 kPa (125 psig) maximum @ -5°C (23°F) 621 kPa (90 psig) maximum @ 50°C (122°F) 345 kPa (50 psig) maximum @ 80°C (176°F)
Process Connection	1 1/2" NPT male
Purge Port Connection	1/4" NPT female. Purge fluid temperature and pressure not to exceed 4909 CPVC temperature and pressure specifications.
Insertion Depth	Varies between 114 mm and 173 mm (4.5" and 6.8") depending on cell constant. For 152 mm (6") additional depth, specify 074344 tube separately.
Overall Length	From process connection: 502 mm (19.7"); 564 mm (22.2") with junction head option.
Total Length Required for Cell Removal	914 mm (36"); 1067 mm (42") if 074344 tube is used.
Wetted Materials	CPVC ball valve, Viton, Teflon & EPDM internal sealing materials, PES cell, nickel, platinum, or monel electrodes, as specified.
Weight	1.6 kg (3.5 lb.)

Warranty/Remedy

Honeywell warrants goods of its manufacture as being free of defective materials and faulty workmanship. Contact your local sales office for warranty information.

If warranted goods are returned to Honeywell during the period of coverage, Honeywell will repair or replace without charge those items it finds defective. The foregoing is Buyer's sole remedy and is **in lieu of all other warranties, expressed or implied, including those of merchantability and fitness for a particular purpose.**

Specifications may change without notice. The information we supply is believed to be accurate and reliable as of this printing. However, we assume no responsibility for its use.

While we provide application assistance personally, through our literature and the Honeywell web site, it is up to the customer to determine the suitability of the product in the application.

Distributor :



Tlf: 67150 250 Faks: 67 150 251

Mail: post@instrumentteam.no

Web: www.instrumentteam.no

For more information, contact Honeywell sales at 1-800-343-0228.

Honeywell

Honeywell Process Control

Honeywell

512 Virginia Drive

Fort Washington, PA 19034