

5000TC Series Toroidal (Electrodeless) Conductivity Sensors

Specification

Overview

The Honeywell 5000TC toroidal (electrodeless) conductivity sensor measures the conductivity of solutions from 0.2 to 2000 millisiemens/cm. The sensors can be used for monitoring chemical concentration and salinity as well. The corrosion and fouling-resistant cells are available with a variety of mounting assemblies to ensure compatibility for applications in the chemical, food & dairy, refinery, pulp & paper, metal finishing and wastewater industries.

Features

- Variety of material types to meet most application needs – PEEK, PFA Teflon®, PVDF, and Polypropylene.
- Increased cell reliability due to high chemical resistance and low friction factor in the materials of construction
- Flexibility of installations with four mounting types – Immersion, Union-mount, Insertion/Removal, and Sanitary
- Temperature-compensated measurement with Pt 1000 ohm RTD
- Convenient for most applications – 20 ft. cable standard
- 3A-approved materials of construction and clean-in-place fitting makes the sanitary type cells suitable for most sanitary applications.

Description

The Honeywell 5000TC sensors are specifically designed for the monitoring of conductivity, chemical concentration, or salinity in difficult applications where coating, fouling, corrosion, or high temperatures/ pressures are a concern. The sensor's 1 1/2" diameter bore minimizes rough surfaces to ensure that flow impedance is minimized. A 1000Ω Pt RTD provides accurate temperature measurement to ensure proper temperature compensation. Two types of basic sensor forms are available with the Honeywell 5000TC – the convertible or sanitary style.

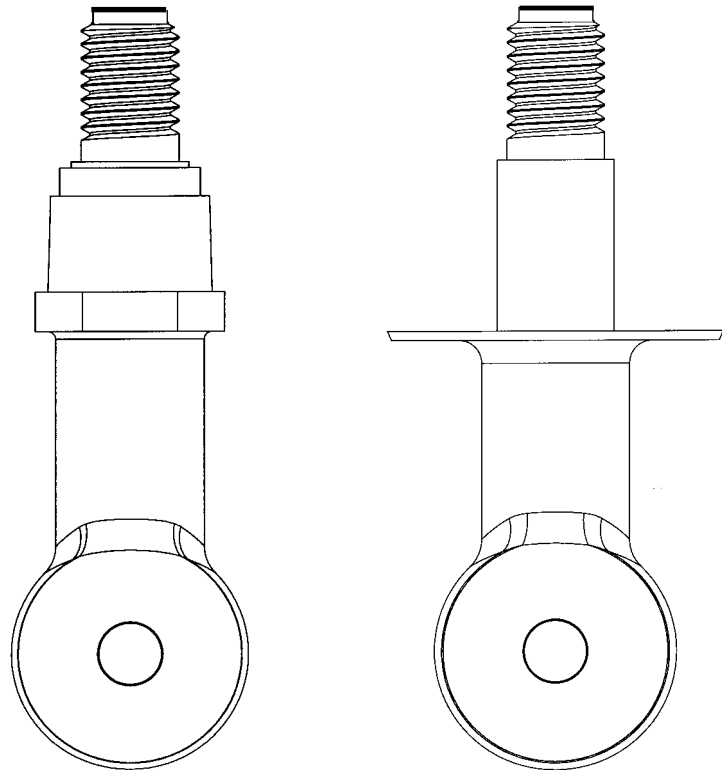

Figure 1 5000TC Convertible & Sanitary Sensors

Convertible Style

The 5000TC convertible style toroidal sensor includes both a 3/4" and a 1/2" fitting to allow direct fastening to the end of a pipe for either immersion mounting or a union-mount adapter for a standard 2" pipe tee. The convertible style can also be insertion mounted into a 2" ball valve assembly. Convertible sensors are available in PEEK, PVDF, PFA Teflon, and Polypropylene materials.

Sanitary Style

The 5000TC sanitary style toroidal sensor includes a clean-in-place style fitting and is constructed of 3A-approved materials. It has an integral 2" sanitary-mount flange which mates to Honeywell sanitary tee mounting hardware. The sanitary-style sensor includes a special cap and EPDM compound gasket. The gasket is also available separately for mounting to a 2" sanitary clamp-type ferrule or butt-weld tee. Sanitary sensors are available in PVDF, PFA Teflon, and Polypropylene materials.

Dimensions for 5000TC Sensors

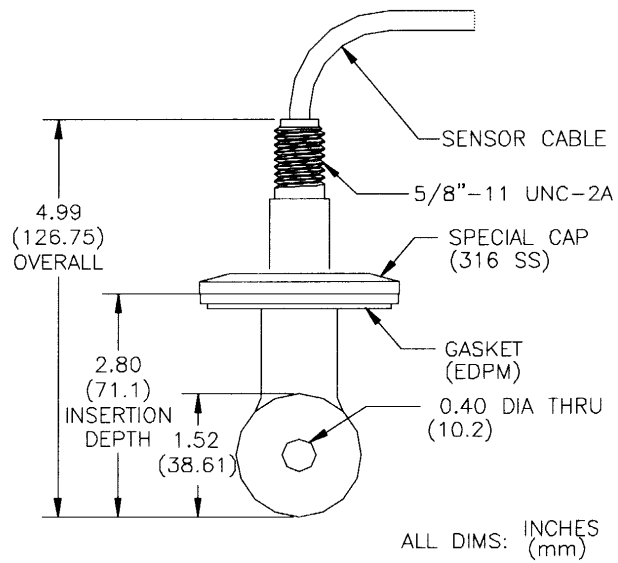

Figure 2 Dimensions for Sanitary Type

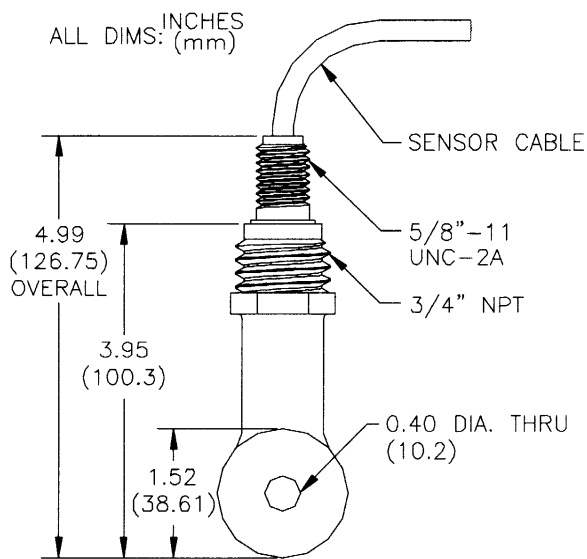

Figure 3 Dimensions for Convertible Type

Wetted Materials

To simplify chemical resistance problems, these sensors are constructed so that only one material is wetted by the process. The wetted material is non-conductive to insure that the sensor is electrically isolated from the process fluid. The 5000TC sensors are available in four different material types – PEEK, PFA Teflon, Polypropylene and PVDF.

PEEK (Polyetheretherketone)	This material type is ideal for the broadest range of applications within the chemical, pulp & paper, and refinery industries. The only known materials to severely attack PEEK are very high concentrations of acids, such as nitric or sulfuric. It has a higher temperature capability than the Polypropylene or PVDF sensors.
PFA Teflon (Perfluoroalkoxy Teflon)	This material type is ideal for extremely corrosive applications, especially high concentrations of sodium hydroxide, nitric acid, sulfuric acid, or hydrofluoric acid. It has the highest temperature rating of the four sensor types. It is also ideal for applications which have a tendency to coat the sensor.
Polypropylene	This material type is ideal for wastewater applications where the temperatures and pressures are close to ambient and chemical compatibility is not a serious concern.
PVDF (PolyVinylidene Fluoride, also called "KYNAR®")	This material type is one of the most rigid and abrasion-resistant materials. It has good chemical resistance to halogens, such as chlorine or bromine. It is ideal for applications which require higher pressure ratings, but do not have high temperatures, such as water treatment applications in the semiconductor industry.

Specifications Common to All Cell Types

Wetted Materials	PFA Teflon, Polypropylene, PVDF, or PEEK								
Operating Temperature Range	10 °C to 125 °C (14 °F to 257 °F)								
Maximum Flow Rate	10 ft. (3 m) per second								
Measuring Range	0.2 to 2000 milliSiemens/cm								
Temperature Compensator	Pt 1000 Ω RTD								
Sensor Cable	5 conductor (plus two isolated shields) cable with XLPE (cross-linked polyethylene) jacket; rated to 150 °C (302 °F); 20 ft. (6 m) long								
Bore Size	1.5" diameter, 0.4" hole								
Pressure/Temperature Limits:									
Sensor Only (no hardware)	<table style="width: 100%; border-collapse: collapse;"> <tr> <td style="width: 30%;">Polypropylene</td> <td>100 psi at 212 °C (6.9 bar at 100 °C)</td> </tr> <tr> <td>PVDF</td> <td>100 psi at 248 °C (6.9 bar at 120 °C)</td> </tr> <tr> <td>PEEK</td> <td>200 psi at 302 °F (13.8 bar at 150 °C)</td> </tr> <tr> <td>PFA Teflon</td> <td>200 psi at 302 °F (13.8 bar at 150 °C)</td> </tr> </table>	Polypropylene	100 psi at 212 °C (6.9 bar at 100 °C)	PVDF	100 psi at 248 °C (6.9 bar at 120 °C)	PEEK	200 psi at 302 °F (13.8 bar at 150 °C)	PFA Teflon	200 psi at 302 °F (13.8 bar at 150 °C)
Polypropylene	100 psi at 212 °C (6.9 bar at 100 °C)								
PVDF	100 psi at 248 °C (6.9 bar at 120 °C)								
PEEK	200 psi at 302 °F (13.8 bar at 150 °C)								
PFA Teflon	200 psi at 302 °F (13.8 bar at 150 °C)								

Mounting Types

The 5000TC sensors are available with a number of different mounting types. These include immersion mounting (CPVC or PVDF materials, also PVC junction box), union mounting (316 SS, CPVC or PVDF materials with optional 2" tee), sanitary mounting (316 SS 2" tee with heavy-duty clamp), or insertion/removal mounting (316 SS or CPVC material).

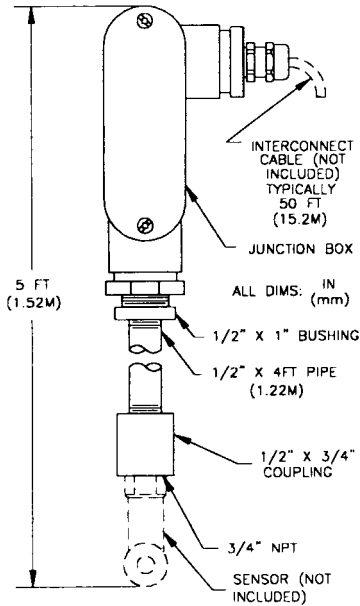

Figure 4 Immersion Mounting

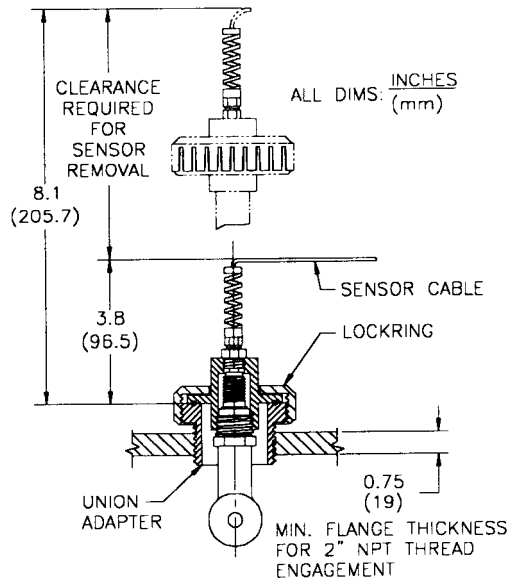

Figure 5 Union Adapter Mounting

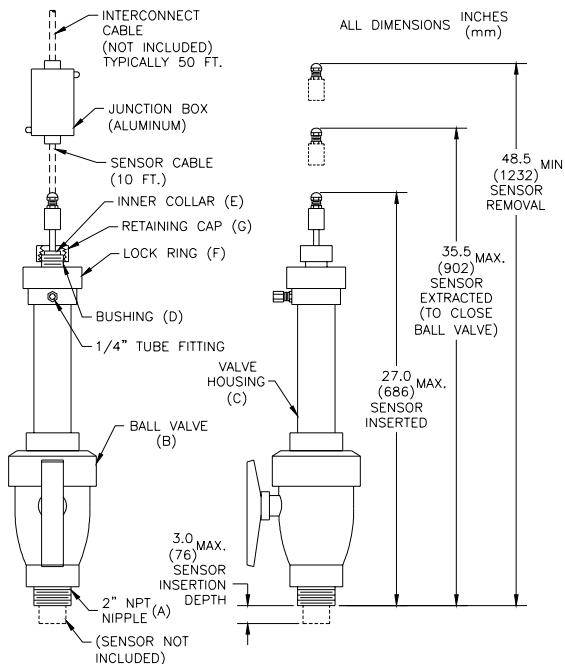

Figure 6 Insertion/Removal Mounting

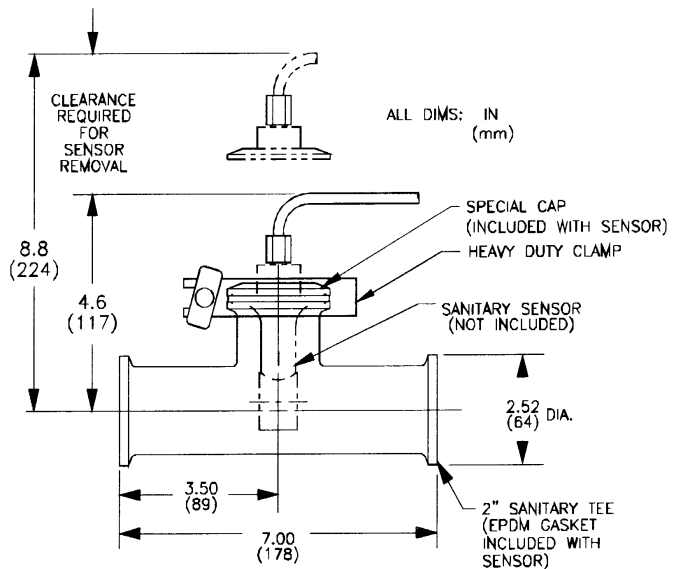
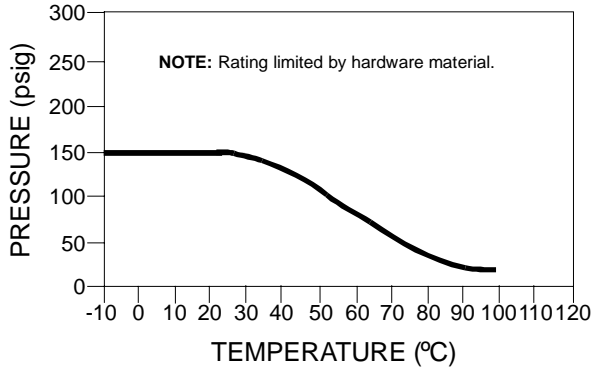

Figure 7 Sanitary Mounting

Basic Mounting Specifications*

**CPVC Mounting Hardware
(all Sensor Materials)**



316 Stainless Steel Sanitary Mounting Hardware
With Polypropylene Sensor**

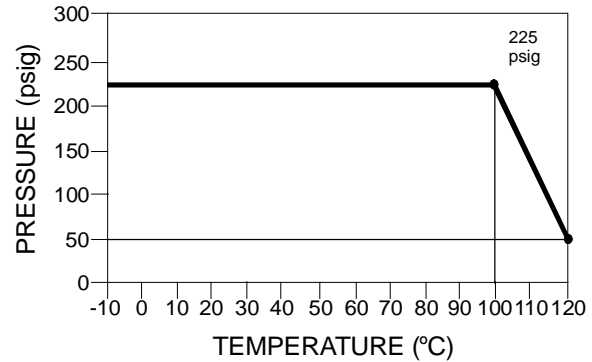

**PVDF Mounting Hardware
(all Sensor Materials)**

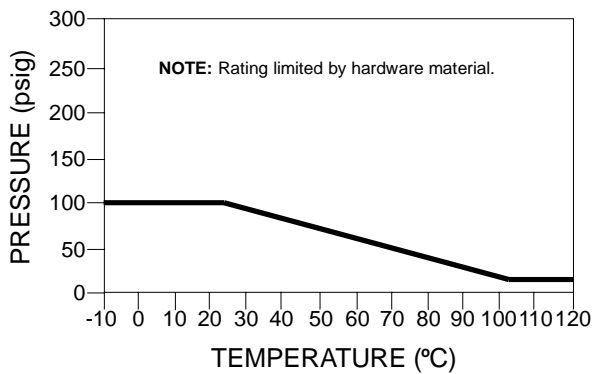

**316 Stainless Steel Sanitary Mounting Hardware
With PVDF Sensor**

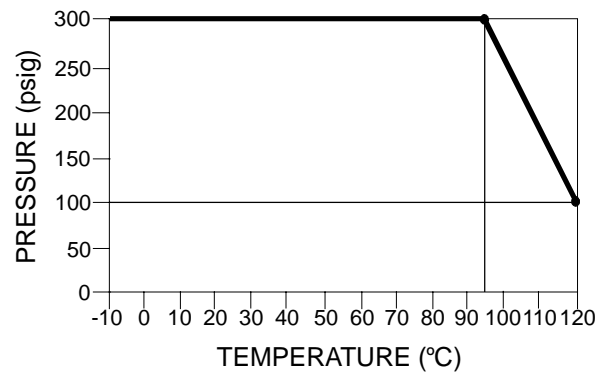

316 Stainless Steel Mounting Hardware

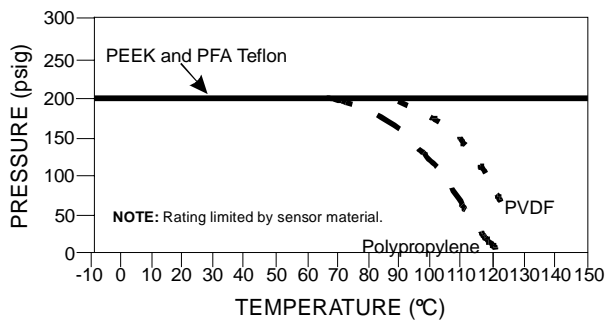

**316 Stainless Steel Sanitary Mounting Hardware
With PFA Teflon Sensor**

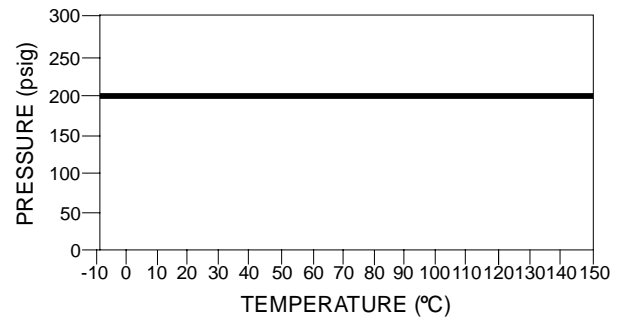

*Ratings for the above Honeywell sensor and mounting hardware combinations are based upon water service. More severe service may require a correction factor. Includes immersion mount, union adapter mount, and sanitary mount. Separate specifications are provided for the insertion/removal device.

**Sanitary mounting hardware ratings are for 51451248-001 hardware using the 51451257-001 heavy duty sanitary clamp. Other hardware and clamp combinations may reduce the listed ratings.

Insertion/Removal Mounting Specifications*

Wetted Materials	Plastic Hardware: Brass, CPVC, Teflon Valve Seats, Viton O-ring Seals Stainless Steel Hardware: 316 Stainless Steel, Teflon Valve Seats, Viton O-ring Seals
Temperature Limits	Plastic Hardware: 23 to 176°F (-5 to 80°C) unsupported if installed vertically; 23 °F to 203 °F (-5 °C to 95 °C) when supported with a bracket** Stainless Steel Hardware: 23 °F to 203 °F (-5 °C to 95 °C) supported or unsupported
Pressure Limits	Plastic Hardware: 50 psi @ 90 °C Stainless Steel Hardware: 100 psi @ 90 °C
Net Hardware Weight	Plastic Hardware: 7.5 lbs. (3.4 kg) Stainless Steel Hardware: 25 lbs. (11.3 kg)

*These sensor/mounting hardware assembly temperature ratings are limited by the hardware material, maximum pressure, and whether the assembly is supported or unsupported.

**The CPVC insertion/removal assembly must be supported with a bracket or strap if it is not installed vertically.

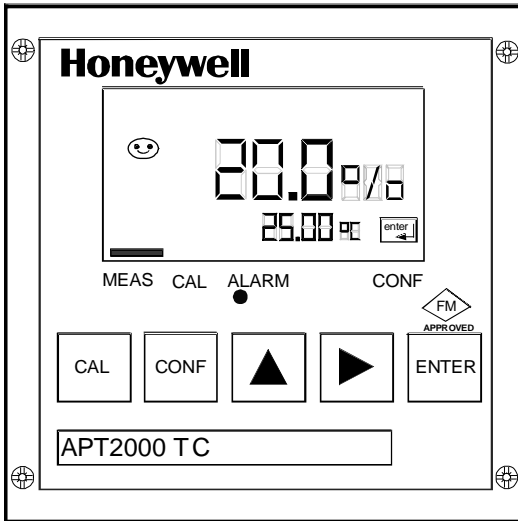

Figure 8 Honeywell APT2000TC Toroidal Conductivity Transmitter

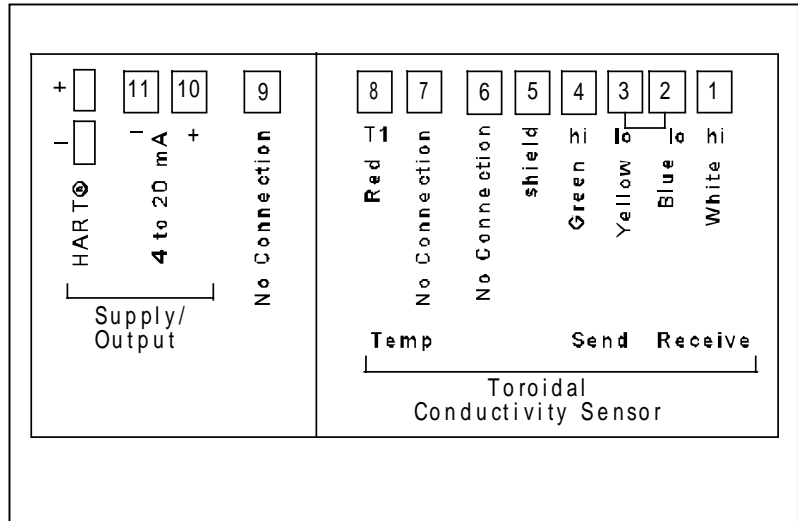

Figure 9 5000TC Wiring Diagram for APT2000TC Transmitter

Toroidal Conductivity Cells Model Selection Guide

51-52-16-54

Issue 1

Instructions

- Make one selection from Table I through IV
- A dot (•) denotes unrestricted availability.

Key Number I II III

┌───┐ - ┌──┐ - ┌──┐ - ┌──┐

KEY NUMBER

Selection Availability

Description		
Toroidal (Electrodeless) Conductivity Probe	5000TC	↓

TABLE I

Mounting	No Mounting Assembly		00	•
Material	CPVC Pipe, PVC Junction Box	51451240-001	11	•
	PVDF Pipe, PVC Junction Box	51451241-001	12	•
Type	316 SS Union Adapter & Standard 2" Tee	51451242-001	21	•
	316 SS Union Adapter Only	51451243-001	22	•
	CPVC Union Adapter & Standard 2" Tee	51451244-001	23	•
	CPVC Union Adapter Only	51451245-001	24	•
	PVDF Union Adapter & Standard 2" Tee	51451246-001	25	•
	PVDF Union Adapter Only	51451247-001	26	•
	316 SS Sanitary 2" Tee & Heavy-Duty Clamp	51451248-001	31	•
	316 SS Insertion/Removal Device	51451249-001	41	•
	CPVC Insertion/Removal Device	51451250-001	42	•

TABLE II

Sensor	No Sensor		0	•
Material	Convertible Polypropylene Sensor	51451251-001	1	a
	Convertible PVDF Sensor	51451252-001	2	a
Type	Convertible PEEK Sensor	51451253-001	3	a
	Convertible PFA Teflon Sensor	51451254-001	4	a
	Sanitary Polypropylene Sensor	51500150-001	5	b
	Sanitary PVDF Sensor	51500151-001	6	b
	Sanitary PFA Teflon Sensor	51500152-001	7	b

TABLE III

Future	None		000	•
--------	------	--	-----	---

ACCESSORIES

51451255-001	6-Conductor Interconnect Cable
51451256-001	6-Conductor Junction Box (comes standard with immersion hardware)
51451257-001	Spare Sanitary Clamp (standard with option 31 from Table I)
51451258-001	Spare Special Cap (standard with option 31 from Table I)
51451259-001	Spare Sanitary Gasket (standard with option 31 from Table I)

RESTRICTIONS

Restriction Letter	Available Only With		Not Available With	
	Table	Selection	Table	Selection
a			I	31
b	I	31		

Warranty/Remedy

Honeywell warrants goods of its manufacture as being free of defective materials and faulty workmanship. Contact your local sales office for warranty information. If warranted goods are returned to Honeywell during the period of coverage, Honeywell will repair or replace without charge those items it finds defective. The foregoing is Buyer's sole remedy and is **in lieu of all other warranties, expressed or implied, including those of merchantability and fitness for a particular purpose.** Specifications may change without notice. The information we supply is believed to be accurate and reliable as of this printing. However, we assume no responsibility for its use.

While we provide application assistance personally, through our literature and the Honeywell web site, it is up to the customer to determine the suitability of the product in the application.

Distributor :



Tlf: 67150 250 Faks: 67 150 251

Mail: post@instrumentteam.no

Web: www.instrumentteam.no

For more information, contact Honeywell sales at 1-800-343-0228.

Teflon is a registered trademark of Dupont

KYNAR is a registered trademark of PennWalt Corporation

Honeywell

Sensing and Control

Honeywell

11 West Spring Street

Freeport, IL 61032