

## DL421/422 DirectLine<sup>®</sup> Sensor for Durafet<sup>®</sup> II and Meredian<sup>®</sup> II pH/ORP Electrodes

70-82-03-40

1/03

Page 1 of 8

## Specification

### Overview

DirectLine<sup>®</sup> DL421/422 for Durafet<sup>®</sup> II pH and Meredian<sup>®</sup> II pH/ORP electrodes is a family of sensors released by Honeywell as part of a new generation of analytical measurement. The DirectLine sensor's unique architecture combines the latest in microelectronics technology with the proven performance of Durafet<sup>®</sup> II solid state pH sensors, or Meredian<sup>®</sup> II glass electrodes, to provide unequaled savings during installation, start-up, operation, and maintenance.

The DirectLine<sup>®</sup> electronics module can mount integrally on the pH/ORP electrode and provide a 4-20 mA dc output proportional to pH. The output of the DirectLine<sup>®</sup> sensor connects directly to any host monitor or control device that accepts standard 4-20 mA

inputs and provides external loop power including:

- Honeywell UDC3300 1/4-DIN Controller
- UMC800 Controller
- PLCs with analog inputs
- DCS systems
- A host of recorder/controller products

For electrode submersion or special mounting applications, the electronics module is also available in a remote-mounting configuration.

### Description

The Honeywell DirectLine<sup>®</sup> architecture consists of an electronics module integral to the electrode. This design eliminates the need and added cost of a separate analyzer or transmitter.

The electronics module is sealed in a plastic weatherproof, corrosion-resistant housing and is connected to the pH/ORP electrode on one side and a 4-20 mA output cable on the other via waterproof connectors. This housing design allows this system to be used in harsh environments where moisture and dust is a problem.

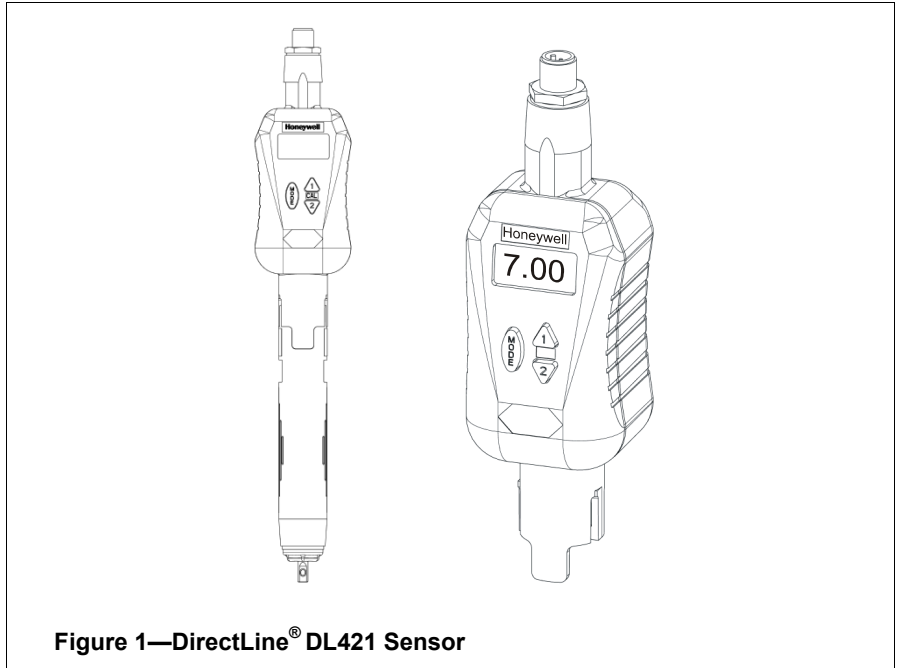

Figure 1—DirectLine<sup>®</sup> DL421 Sensor

### Description, continued

For submersion or special mounting applications, the remote mounting option connects the electronics module to the electrode via a cable. The electronics module is then mounted on a 2-inch pipe, wall, or DIN rail.

### Features

- **Direct 4-20 mA output** eliminates need for dedicated analyzers or transmitters, simplifying installation, start-up, operation, and maintenance tasks. Installation costs are also reduced because standard cable can be used for additional cable distances.
- **Integral electronics with local HMI** simplifies installation and shortens calibration times.
- **Modular plug-in construction** simplifies electrode replacements.
- **Local display and keypad** facilitates quick set-up, calibration, and operational activities.
- **½" NPT conduit connection** provides increased protection and noise immunity of output cable

### Features, continued

- **Plug-in modular design** allows sensor to be safely removed and replaced without cycling power on the electronics module.
- **Electronics and sensor diagnostics** reduces troubleshooting times.
- **Sample or auto buffer calibration options** accommodates individual calibration techniques and reduces calibration time.
- **Playing card-sized guide** facilitates simple, correct, and consistent calibration and configuration.
- **Watertight sensor connection** for reliability in submersion applications.
- **Global approvals** including:
  - CE Mark for industrial applications
  - UL General Purpose
  - CSA General Purpose
  - FM Class I, Div. 1 (I.S.)
  - FM Class I, Div. 2 (non-incendive field wiring)
  - IP66, Type 4x Enclosure

## Electronics Module

### *Integral Electronics/Sensor Design*

The DirectLine® electronics module is loop-powered by 16-42 Vdc source and will modulate its supply current from 4-20 mA, depending upon the pH or ORP value sensed by the electrode. The output cable connects to the electronics module by a waterproof connector. The DirectLine® sensor's output cable connector is a standard M12 type receptacle. The M12 receptacle easily connects to a cord set with an M12 connector or an M12 field wiring connector and customer-supplied cable.

The DL421/422 module quickly attaches to the electrode and is easily locked-in-place for assured safety and reliability during operation. The electrode can be removed from the module safely without disrupting power to the electronics.

### *Submersion Applications*

For submersion or special wiring applications, a remote electronics module option is available. The remote electronics module is mounted on a 2-inch pipe, wall, or DIN rail. The remote sensor cable directly connects the electronics module to the sensor with a submersible connector. The remote sensor cable is available in 20-ft. or 50-ft. lengths for the Durafet® II electrode, or in 12-ft. or 20-ft. lengths for the Meredian® II pH/ORP electrode.

## Operator Interface

The DirectLine® electronics module configuration, calibration, and maintenance functions are performed locally from three buttons and a 4-digit, 7-segment LCD display on the front side of the electronics module. The process variable, temperature (if available), and any error diagnostics are viewable from the local LCD display.

The following configuration functions are available.

- Zero (Standardization) calibration
- Slope calibration (for pH only)
- Buffer group selection for Auto Buffer Recognition (for pH only)
- Solution temperature coefficient selection (for pH only)
- Output configuration
- Noise suppression frequency selection

The Honeywell DirectLine® sensor eliminates the extra time needed to travel back and forth between the analyzer/transmitter and sensor while performing a calibration. The DL421 for pH offers two calibration options: Sample or Auto Buffer Recognition. In addition, you can elect to do a one or two-point calibration. Standard buffer tables are available in the software to help simplify and reduce your calibration setup time.

A playing card-sized guide comes with each DirectLine® sensor to guide you through a configuration or calibration quickly.

## Online Diagnostics

The DirectLine® sensor continuously performs self-diagnostics on both the electronics and sensor. These prioritized self-diagnostics help to minimize the time and expense of troubleshooting during start-ups, maintenance, and calibrations.

If a problem arises with either the module electronics or the sensor, the software prioritizes the problem type and displays only the highest priority error diagnostic thus simplifying the troubleshooting process. Once the diagnostic is corrected, the error code disappears from the display.

## Online Diagnostics, continued

If the electrode's temperature or process variable value goes out of operation range, the output current is driven to approximately 21.8 mA to inform the host device of a problem. Once the problem is corrected, the output current is returned back to normal and the error code disappears. Error codes are also used to indicate calibration failures.

For pH measurement a special zero offset and percent theoretical slope calibration diagnostic updates automatically at completion of each calibration. The operator can monitor these diagnostics to determine when the sensor is no longer capable of holding a good calibration.

## Durafet® Electrodes

Durafet® II electrodes feature state-of-the-art pH measurement technology, using an ISFET (Ion Sensitive Field Effect Transistor) sensing element. This virtually unbreakable, industrial solid state pH electrode provides especially fast response for improved product quality. Durafet® sensors produce a direct low impedance pH signal for outstanding reliability even at low temperatures and with no sodium error or ORP interference. The Durafet® pH electrode incorporates a replaceable reference junction frit and gel, assuring long life even in the most highly fouling applications.

Features include:

- ISFET technology provides an exceptionally fast response for improved product quality.
- Virtually unbreakable for lower replacement costs.
- Reference junction frit and gel are replaceable for longer electrode life.
- Low impedance pH signal.
- Low impedance pH signal for improved product reliability.
- One electrode for entire pH and temperature ranges results in lower inventory costs.

## Specifications

<b>Displayed Process Variable</b>	<i>pH</i> : 0-14 pH <i>ORP</i> : -1600 to +1600 mV
<b>Displayed Temperature Range (pH only)</b>	-10 °C to +110 °C (14 °F to 230 °F)
<b>Display Accuracy (reference)</b>	<i>pH</i> : ±0.02 pH <i>ORP</i> : ±1 mV
<b>Process Temperature</b>	<i>Durafet</i> ®: -10 °C to +110 °C (14 °F to 230 °F) <i>Meredian</i> ®: 0 °C to 110 °C (32 °F to 230 °F)
<b>Durafet® Sensor Survivable Temperature Range</b>	-10 °C to +130 °C (14 °F to 266 °F)
<b>Electronics Module Ambient Temperature</b>	-20 °C to +85 °C (-4 °F to +185 °F)
<b>Output Type</b>	4-20 mA (2-wire loop powered)
<b>Output Scale</b>	0-14 pH, ±1600 mV
<b>Output Calibration</b>	4-20 mA
<b>Durafet® Remote Mating Connector Rating</b>	Submersible to 20 feet
<b>Output (Loop) Cable Connection</b>	M12 type
<b>User Termination</b>	Tinned leads on cord set or customer supplied cable
<b>Cable Lengths</b> <b>Sensor:</b>  <b>Output:</b>	<i>Durafet</i> ®: 20 feet or 50 feet <i>Meredian</i> ®: 12 feet or 20 feet 20 feet or 50 feet
<b>Power</b>	16-42 Vdc <i>Maximum Load Resistance:</i> 250 ohms at 16 Vdc 600 ohms at 24 Vdc 1400 ohms at 42 Vdc
<b>Local Display and Buttons</b>	LCD 4-digit, 7-segment
<b>Engineering Units</b>	pH, mV degrees F degrees C
<b>Calibration Options (pH)</b>	1 point Sample or 2 point Sample Auto Buffer Recognition <i>Selections:</i> US, NIST, EURO
<b>Solution Temperature Compensation (for pH only)</b>	<i>Selections:</i> 0.00pH/10 °C -0.16pH/10 °C -0.32pH/10 °C
<b>Diagnostics</b>	Sensor and electronics
<b>Case</b>	Weatherproof, corrosion-resistant plastic housing
<b>Approvals</b>	CE Mark for Industrial Applications UL – General Purpose CSA – General Purpose FM Class I, Div. 1, Groups A, B, C, D and Class I, Zone 0, AEx ia IIC (I.S.) FM Class I, Div. 2, Groups A, B, C, D; Class I, Zone 2, Groups IIC (non-incendive field wiring) Enclosure: IP66, Type 4x
<b>Remote Mounting</b>	Pipe, Wall, or DIN Rail
<b>Dimensions</b>	H 123 mm (4.84") x W 48 mm (1.89") x D 46 mm (1.81")
<b>Weight</b>	Approximately 142 g (5.0 oz.)

**Dimensions**

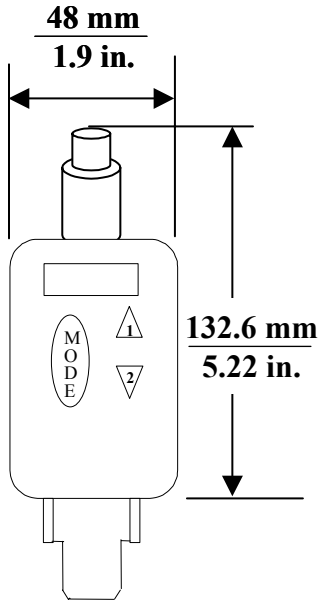

**Front View**

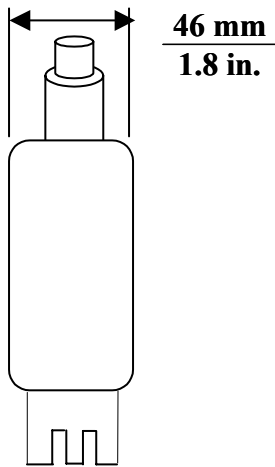

**Side View**

**Figure 2—Dimensions**

**Mounting**

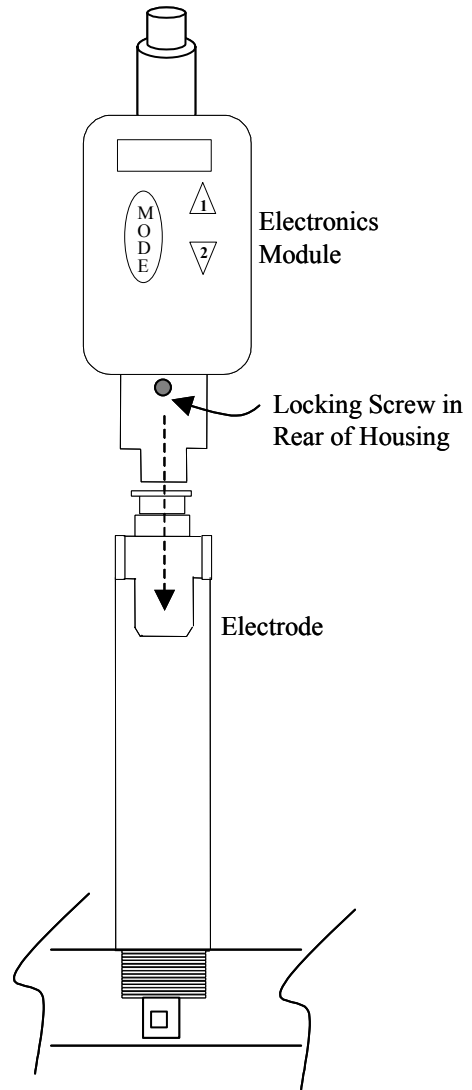

**Figure 3—Integral Mounting**

### Remote Mounting

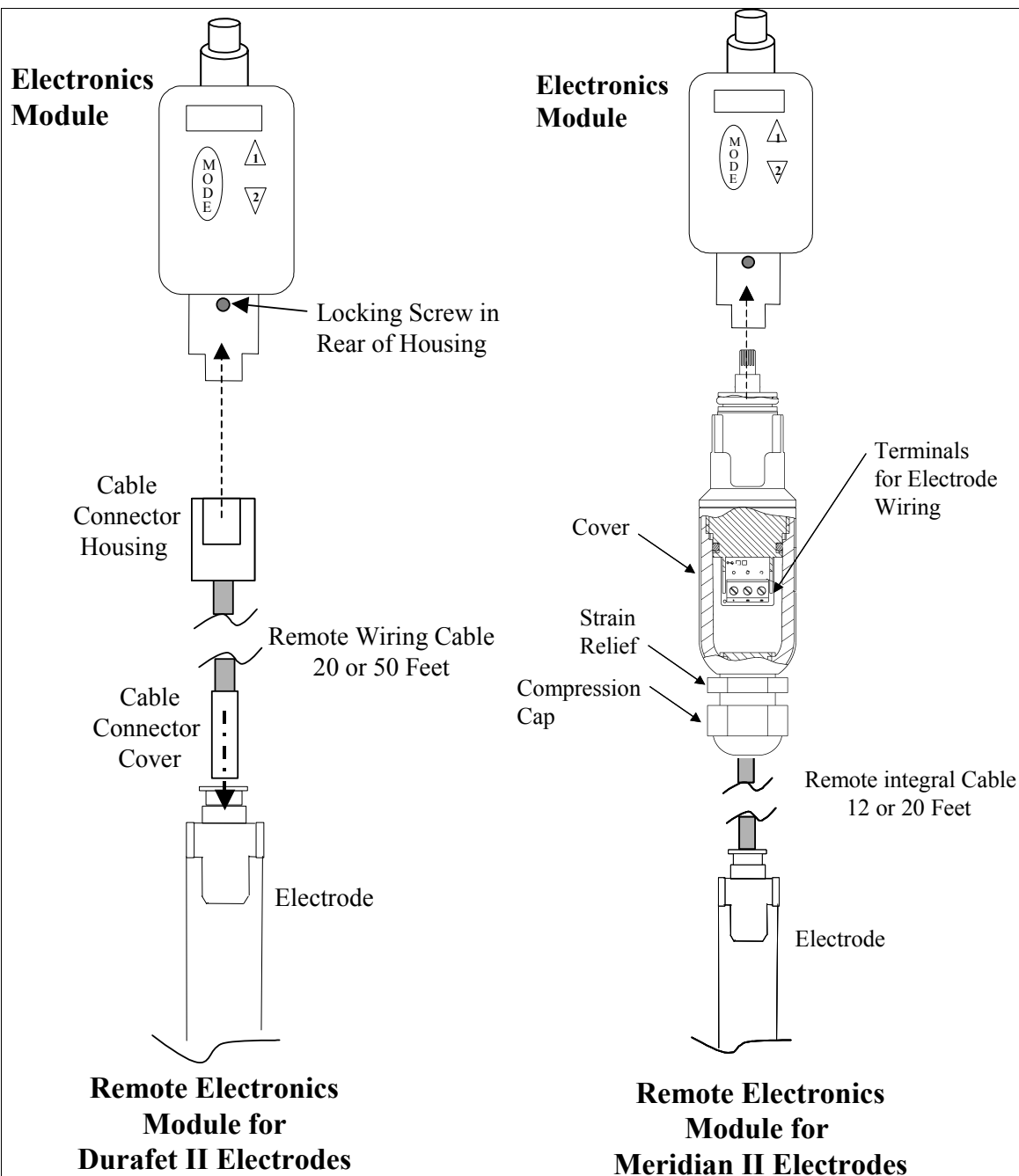
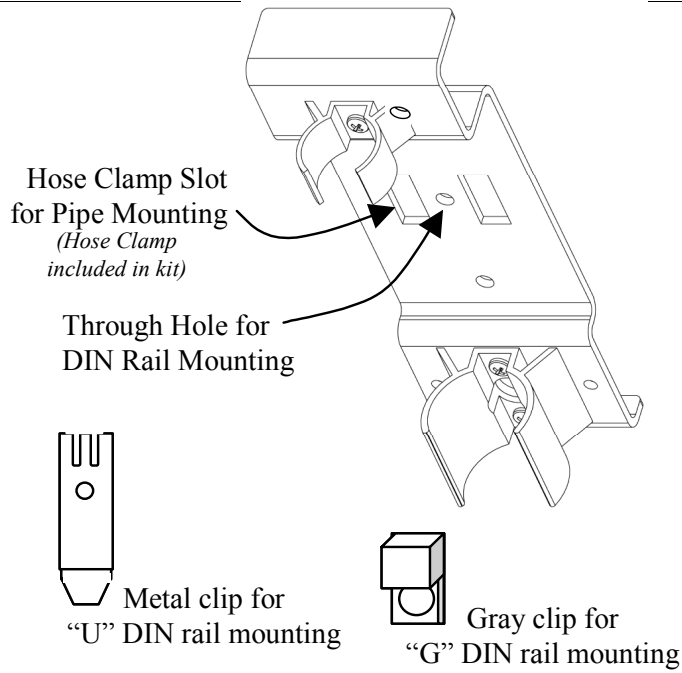

Figure 4—Remote Mounting

### Remote Mounting Hardware



### Mounting Kit

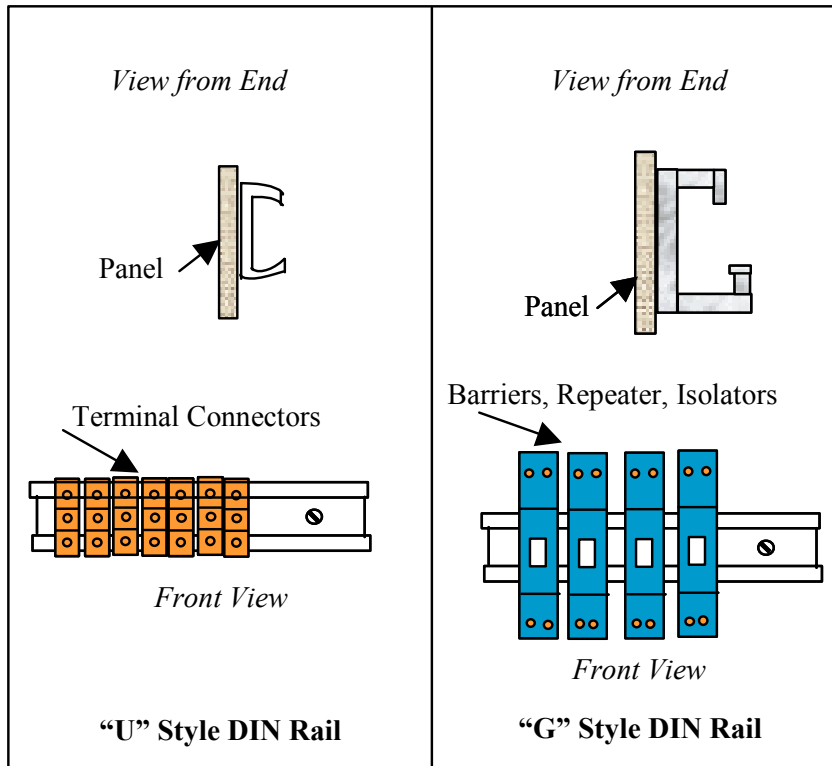
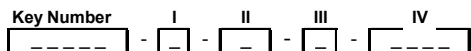

Figure 5—Remote Mounting Hardware

## Model Selection Guide

### Instructions

- Select the desired key number. The arrow to the right marks the selection available.
- Make the desired selections from Tables I through IV using the column below the proper arrow. A dot (•) denotes availability.



### Key Number - DirectLine® Sensor Electronics Module

(Specify electrodes/cells/probes separately)

		Selection	Availability			
pH	For use with Durafet II, Meredian II & HPW7000 pH electrodes	DL421	↓			
ORP	For use with ORP electrode.	DL422		↓		
Conductivity	For use with Contacting Conductivity Cells	DL423			↓	
DO - PPM	For use with Dissolved Oxygen ppm Probes	DL424				↓
DO - PPB	For use with Dissolved Oxygen ppb Probes	DL425				↓

**TABLE I - OUTPUT CABLE**

Output Cable for Integral or Remote Mounting	None (replacement module or customer supplied output cable)- <b>Note 1</b> Cordset - 6m (19.7 ft.) - includes connector and cable - <b>Note 2</b> Field Wiring Connector <b>only</b> - customer supplies cable only- <b>Note 2</b>	D	E	F
		•	•	•
		•	•	•
		•	•	•

**TABLE II - SENSOR CABLE/REMOTE CONNECTOR (between electronic module and electrode, sensor or probe)**

Integral Mounting	None cable or connector required	0	d	d	d	d	d
Remote Mounting Cable - Durafet only	6,096m (20 ft.) of sensor cable - Durafet II Remote Mounting	1	e				
	15,24m (50 ft.) of sensor cable - Durafet II Remote Mounting	2	e				
Remote Mounting Connector (Cable is supplied with sensor or probe)	Remote Mounting Connector - Meredian II pH	3	e				
	Remote Mounting Connector - Meredian II ORP	3		e			
	Remote Mounting Connector - HPW7000	4	e				
	Remote Mounting Connector - Conductivity	5			e		
	Remote Mounting Connector - Dissolved Oxygen	6				e	e

**TABLE III - REMOTE MOUNTING OPTIONS**

Mounting Kit for Remote Mounting	None Integral unit - mounting not required 2" (5,08 cm) Pipe mtg. bracket, wall mtg. & DIN Rail clip	A	B
		•	•
		•	•

**TABLE IV - OPTIONS**

Tagging	None Linen Customer ID Tag - 3 lines w/22 characters/line SS Customer ID Tag - 3 lines w/22 character/line	00__	LT__	SS__	__00	__CC
		•	•	•	•	•
		•	•	•	•	•
		•	•	•	•	•
		•	•	•	•	•

**Notes:**

- 1 Customer supplies cordset **or** cable with M12 connector. Suppliers & P/Ns include:

	Phoenix Contact	Turck
Cord-set	SAC-3P-5.0-PUR/M12FSSH Stainless	RKV4T-6/S618
M12 Field Wiring Connector	SACC-M12FS-4CON-PG7	B8141-0
Cable	2-wire twisted shielded pair	

- 2 Recommended cable is 2-wire twisted shielded pair

**RESTRICTIONS**

Restriction Letters	Available Only With		Not Available With	
	Table	Selection	Table	Selection
d	III	A		
e	III	B		

**ORDERING INSTRUCTIONS:**

- Part numbers are provided to facilitate Distributor Stock.
- Orders may be placed either by model selection or by part number.
- Part numbers are shown within the model selection tables to assist with compatibility information.
- Orders placed by model selection are systematically protected against incompatibility.
- Compatibility assessment is the responsibility of the purchaser for orders placed by part number.
- Items labeled as N/A are not available via the stocking program and must be ordered by model selection.

---

## Warranty/Remedy

---

Honeywell warrants goods of its manufacture as being free of defective materials and faulty workmanship. Contact your local sales office for warranty information. If warranted goods are returned to Honeywell during the period of coverage, Honeywell will repair or replace without charge those items it finds defective. The foregoing is Buyer's sole remedy and is **in lieu of all other warranties, expressed or implied, including those of merchantability and fitness for a particular purpose**. Specifications may change without notice. The information we supply is believed to be accurate and reliable as of this printing. However, we assume no responsibility for its use.

While we provide application assistance personally, through our literature and the Honeywell web site, it is up to the customer to determine the suitability of the product in the application.

Distributor :



Tlf: 67150 250 Faks: 67 150 251

Mail: [post@instrumentteam.no](mailto:post@instrumentteam.no)

Web: [www.instrumentteam.no](http://www.instrumentteam.no)

For more information, contact Honeywell sales at 1-800-343-0228.

---

# Honeywell

### Industrial Measurement and Control

Honeywell  
1100 Virginia Drive  
Fort Washington, PA 19034