

# 7866 Digital Thermal Conductivity Analyzer for Binary Gas Mixtures

# Specification

## Overview

The Honeywell 7866 Thermal Conductivity Analyzer is designed to provide a highly sensitive and accurate analysis of a binary (2-component) mixture of gases. The analyzer can also be calibrated to measure a single component of a multicomponent gas mixture, providing the background gases constitute a stable mixture (such as air), or have approximately the same thermal conductivity.

The 7866 analyzer uses the principles of thermal conductivity, to determine the concentration of a sample gas through the measurement of thermal losses from two highly stable, matched thermistor probes inserted in a stainless steel block

## Features

- Easy to use prompts
- Security code protected
- Reliable solid state design
- High speed of response
- High sensitivity
- Excellent stability
- Low maintenance requirement
- Low installation costs through optional remote mounting capability of the sensing unit (transmitter)
- Explosion-proof housing on the sensing unit available
- Signal transmission from the sensing unit up to 1000 feet over unshielded leadwires
- Panel-mounted 1/4 DIN control unit (receiver) with easy-to-read display
- Current output signal from the control unit representing measured PV
- Single or dual alarms
- A triple range analyzer for hydrogen-cooled generator applications is available

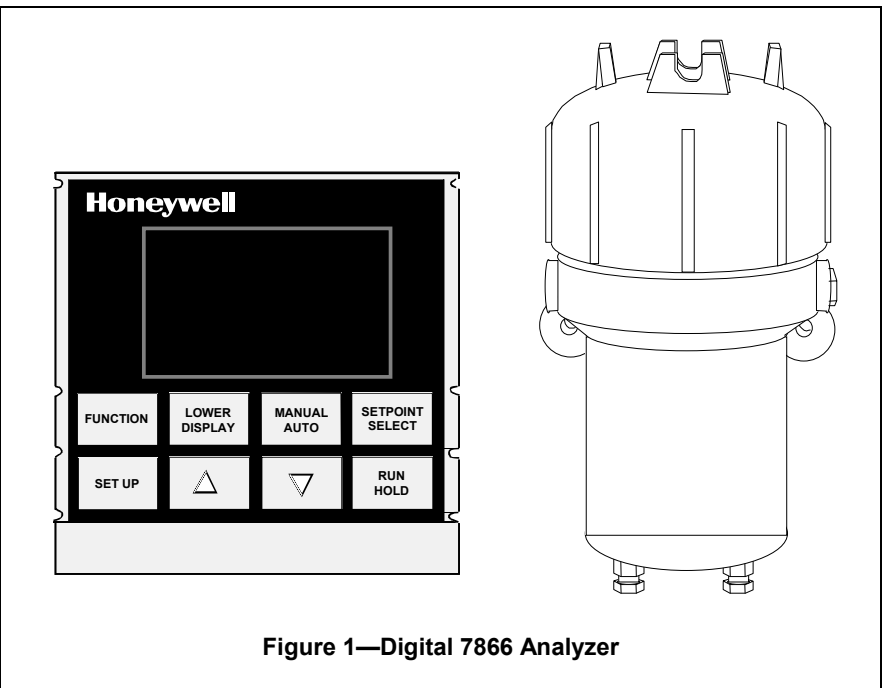
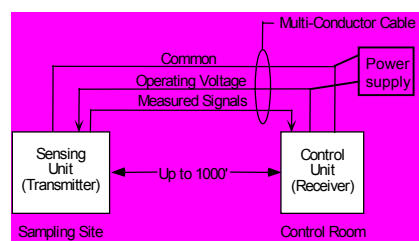

Figure 1—Digital 7866 Analyzer

- Triple range analyzer has available a second current output used to retransmit ranging data to optional indicator model (mutually exclusive with Alarm 2)
- Optional Modbus communications supports configuration and data acquisition

## Description

The analyzer consists of three basic components: the sensing unit (transmitter), the control unit (receiver) and a power supply.



The sensing unit receives a continuous flow of the binary or multi-component gas mixture, measures the concentration of the sample gas and transmits an electrical signal to the control unit. The sensing unit is ruggedly constructed to meet most environmental conditions and is designed to be mounted up to 1,000 feet from the control unit with only a single multi-conductor non-shielded cable connecting the two, resulting in greater flexibility and lower installation costs.

The control unit receives the output signal from the sensing unit at the sampling site by way of the inter-connecting cable.

The control unit is designed for simplified panel-mounting either at the sampling site, if environmental conditions permit, or in a control room. The unit provides a current output signal to a remote device for monitoring or recording purposes.

The control unit is supplied with one or two alarms. When an alarm is detected, the specific relay de-energizes creating an open circuit that can activate an external annunciator or a relay to initiate a shutdown procedure for the process. When power is off the alarm relay is de-energized and the normally open contact is non-conducting (open).

An indicator model, which provides a continuous readout of the concentration of the gas under analysis, is available with the triple range 7866 analyzer. The indicator input is connected to the controller's current output. The indicator has no direct connection to the sensing unit.

Some common applications of the 7866 Thermal Conductivity Analyzer are:

- *Electric Power Industry Power Plants* – Accurate monitoring of hydrogen purity in hydrogen-cooled generators. The triple range analyzer also monitors carbon dioxide in air and carbon dioxide in hydrogen insuring safe execution of the purge cycles.
- *Chemical Industry* – Measurement of hydrogen in ammonia or nitrogen for dissociated ammonia applications. Also, measurement of hydrogen in oxygen, carbon dioxide, and methane.
- *Petroleum Industry* – Measurement of hydrogen in certain hydrocarbon streams.

## Equipment

**Sensing Unit** – The 7866 Thermal Conductivity analyzer's sensor assembly is supplied with an optional explosion proof housing. The housing consists of a rugged cast aluminum construction that permits reliable operation under adverse ambient conditions.

The sensor assembly consists of two sections – the cell block assembly and the electronic assembly.

The cell block assembly is of stainless steel construction with two identical internal cells, the measuring cell and the reference cell. The highly stable thermistor is mounted in each cell. These matched thermistors form the active arms of a bridge circuit. The unbalanced current of the bridge provides the means of measuring the relative ability of the sample and reference gases to conduct the heat away from their respective thermistors to the cell wall, which is held at a constant temperature. The reference gas chamber, with inlet and outlet openings drilled into the chamber from the base, can be opened or sealed. All zero-based standard ranges and the 20 % to 50 % H<sub>2</sub> range have air-filled, sealed reference cells. For hydrogen ranges starting above 50 % as well as the 90-100 % oxygen range, a flowing reference is used. The measuring chamber is open to the continuous sample gas flow.

The cells in which the thermistors are mounted are dead-ended so the sample gas enters only by diffusion, minimizing the effect of sample flow variations. In addition, the entire cell-block assembly is maintained at a constant optimum temperature through two heaters and a control thermistor that are located in the cell block assembly.

The sensing unit's electronics assembly incorporates solid state electrical circuits. These circuits include:

- *Current Regulator* which supplies the constant current to the thermistor cell bridge circuit.
- *Proportional Action Temperature Controller* which maintains the entire cell block at a constant temperature.
- *Voltage to Current Converter/ Amplifier* whose current output is transmitted to the analyzer's Control Unit.

**Control Unit** – The control unit houses the remaining measuring circuits in an extruded aluminum 1/4 DIN standard case. In addition, the control unit contains the front-panel calibration adjustments for the analyzer system. This includes the zero and span adjustments.

*Digital Display on the Control Unit* – Provides a continuous readout of the concentration (0-100 %) of the gas under analysis.

*Dual Alarms* – Two alarms are available for high and low alarms. Each alarm can be individually set. An alarm hysteresis which sets the deactivation range for both alarms is also available. The alarms include numeric indication on the display, as well as, an external relay contact for external communication. The relay output can also service an external shutdown device.

*Optional Modbus Communications* – Allows the controller to be connected to a host computer via the Modbus protocol.

### **WARNING**

When measuring flammable gas mixture that contains oxygen, the maximum oxygen concentration must not exceed 21%.

- Upper Display** - six characters
- Normal Operation - four digits dedicated to displaying the process variable (Decimal place is selectable to either 1 or 2 places)
  - Configuration Mode - displays parameter values or selection
- Lower Display** - eight characters
- Normal Operation -
    - **Single Range:** displays RANGE1 or the gas prompt
    - **Triple Range:** displays either RANGE x (x = selected range 1, 2, 3) or the equivalent gas prompt
  - Configuration Mode - displays the group or function prompt

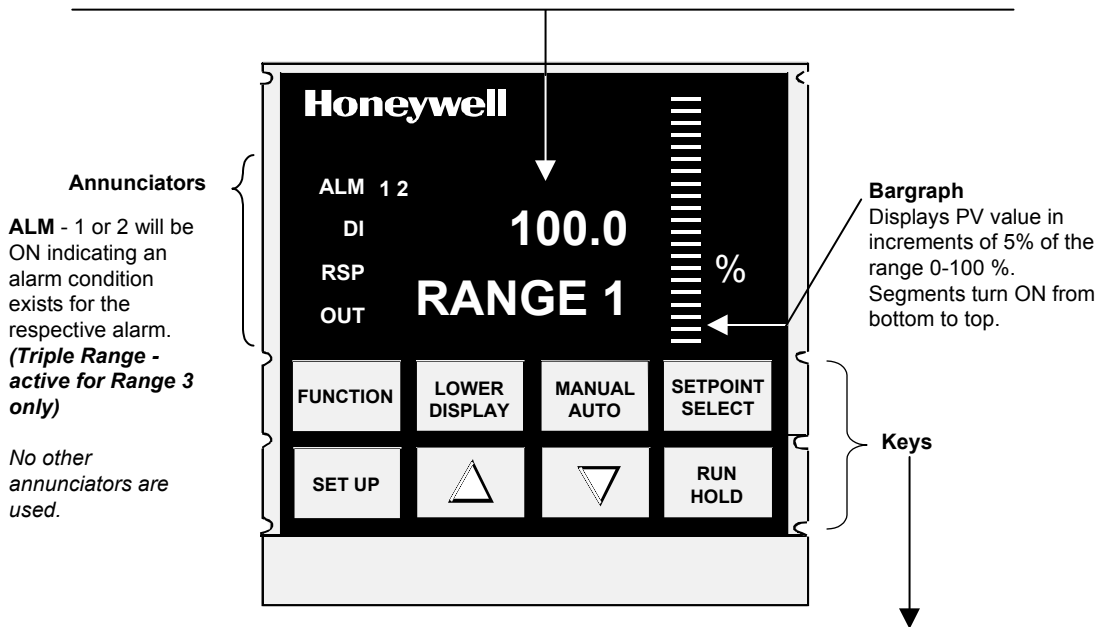



<b>SET UP</b>	<ul style="list-style-type: none"> <li>• Places the controller in the Configuration Set Up group select mode. Sequentially displays Set Up groups and allows the FUNCTION key to display individual functions in each Set Up group.</li> </ul>
<b>FUNCTION</b>	<ul style="list-style-type: none"> <li>• Used in conjunction with the SET UP key to select the individual functions of a selected Configuration Set Up group.</li> <li>• Pressing this key saves, into nonvolatile memory, any changes made to previous function value or selection.</li> <li>• Used during field calibration procedure.</li> </ul>
	<ul style="list-style-type: none"> <li>• <i>Configuration Mode:</i> Used to scroll through the parameter selections or to increase the selected parameter value.</li> <li>• Used during field calibration procedure.</li> </ul>
	<ul style="list-style-type: none"> <li>• <i>Configuration Mode:</i> Used to scroll through the parameter selections or to decrease the selected parameter value.</li> <li>• Used during field calibration procedure.</li> </ul>
<b>SETPOINT SELECT</b>	<ul style="list-style-type: none"> <li>• <b>Triple Range: Normal Operation:</b> Used to toggle what is shown in the lower display—either the Range being measured or its corresponding Gas.</li> <li>• <b>Single Range:</b> Unused key—KEY ERR message appears in lower display if key is pressed.</li> </ul>
<b>LOWER DISPLAY</b>	<ul style="list-style-type: none"> <li>• <b>Triple Range:</b> <ul style="list-style-type: none"> <li>• <i>Normal Operation:</i> Used to scroll through the lower display selections:               <ul style="list-style-type: none"> <li>• If Range was selected (by pressing SETPOINT SELECT), selections are <b>RANGE 1, RANGE 2, or RANGE 3</b>.</li> <li>• If Gas was selected (by pressing SETPOINT SELECT), selections are <b>CO2inAIR, H2in CO2, H2in AIR</b> (corresponding to Range 1, Range 2, and Range 3 respectively).</li> </ul> </li> </ul> </li> <li>• <b>Single Range:</b> <ul style="list-style-type: none"> <li>• Used to toggle between <b>RANGE 1</b> and the Input Type [e.g., <b>PC H2</b> (Percent Hydrogen)] during normal operation.</li> </ul> </li> </ul>
<b>MANUAL AUTO</b> <b>RUN HOLD</b>	<ul style="list-style-type: none"> <li>• Unused keys</li> <li>• KEY ERR message will appear in lower display if one of these keys is pressed.</li> </ul>

Figure 2—7866 Control Unit Operator Interface and Key Functions



**Figure 3—7866 Sensor Assembly**

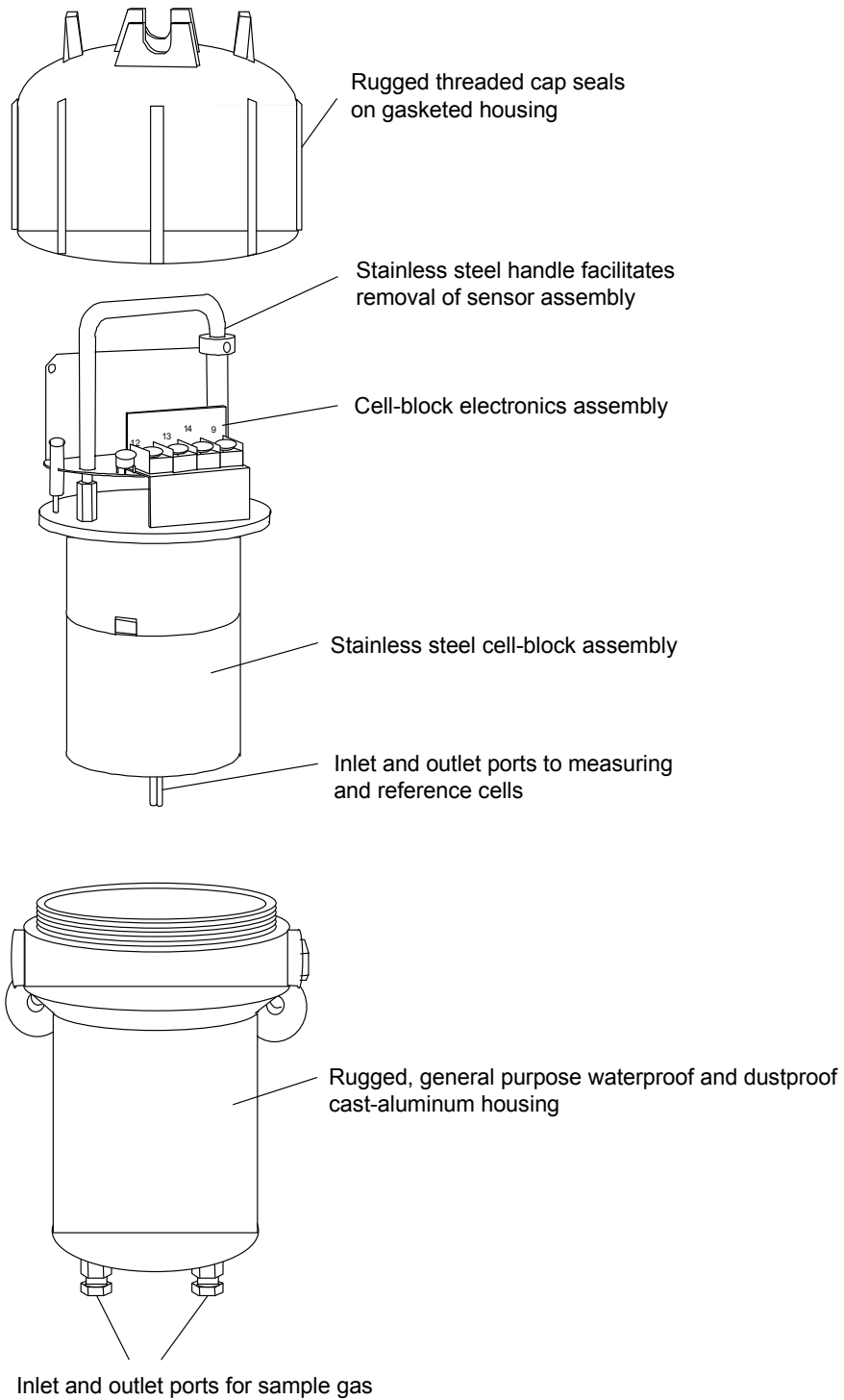
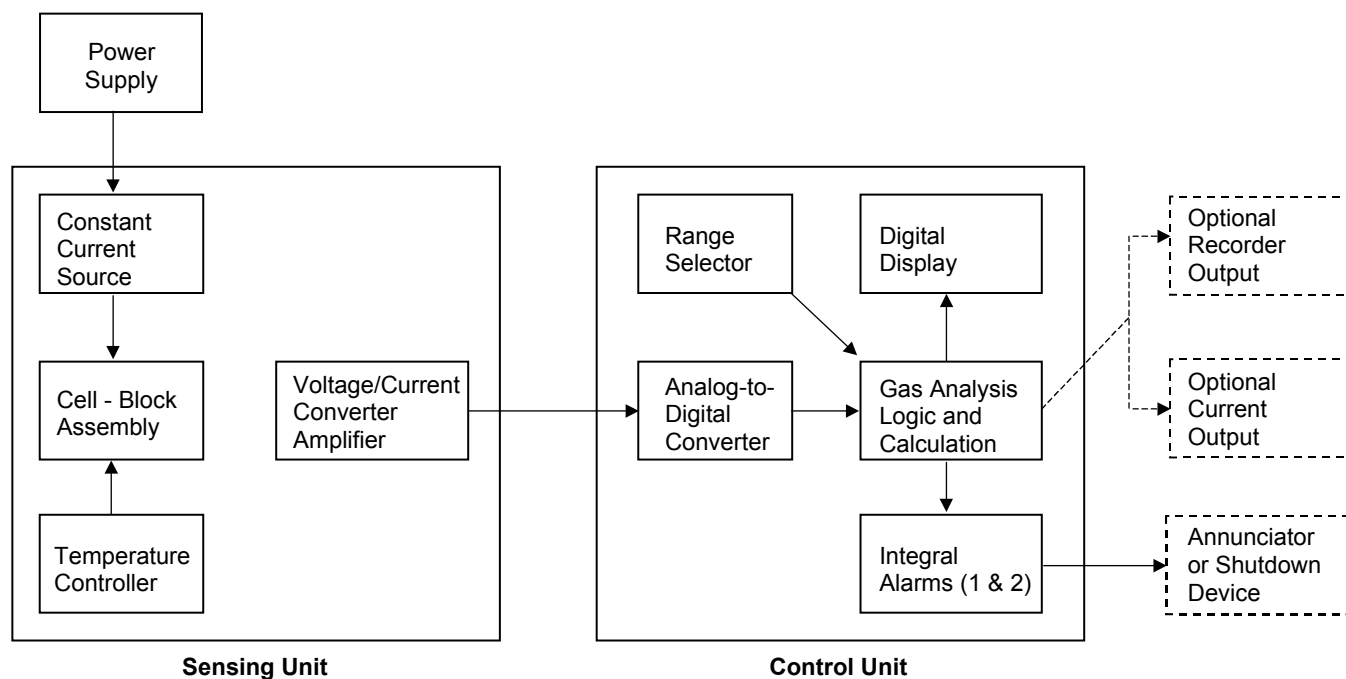

Figure 4 Block Diagram of 7866 Digital Thermal Conductivity Analyzer

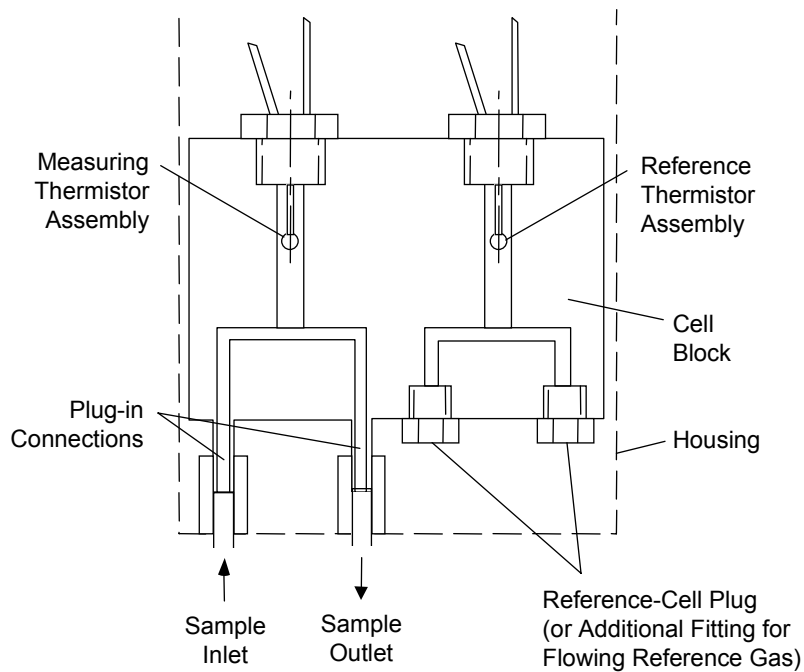



Figure 5—Cross-Section of 7866 Sensing Unit

## Specifications

Performance	
<b>Accuracy</b>	± 2 % of span (output signal) at reference conditions for binary gas mixtures
<b>Linearity</b>	Within ± 2 % of span for most standard ranges. If linearity exceeds ± 2 % a correction curve is supplied with the analyzer.
<b>Meter</b>	<i>Accuracy:</i> ± 2 % of span <i>Digital Indication:</i> ± 0.1 %
<b>Repeatability</b>	Short term: ± 0.3 % of span
<b>Reproducibility</b>	24 hour: ± 1 % of span
<b>Response Time</b>	Maximum, for 4 cfh (2000 cc/min.) flow: For H <sub>2</sub> ; initial, less than 1 second; 63 %: 13 seconds 90 %: 23 seconds 99 %: 40 seconds  For CO <sub>2</sub> ; Initial, less than 2 seconds; 63 %: 24 seconds 90 %: 45 seconds 99 %: 80 seconds
<b>Maximum Drift</b>	<i>Zero:</i> ± 2 % of span per week maximum <i>Span:</i> ± 2 % of span per week maximum
<b>Ambient Temperature Influence</b>	<i>At sensing unit:</i> Depends on range; typically less than 1 % F.S. over entire temperature range <i>At control unit:</i> ± 0.01% per °C (± 0.005 % of span per °F)
<b>Atmospheric Pressure Influence</b>	± 0.01 % of span per inch H <sub>2</sub> O (± 0.05 % of span per mm Hg)
<b>Sample Flow Rate Influence</b>	Less than ± 0.5 % of span over flow range of 0.2 to 4 cfh (100 to 2000 cc/min)
<b>Line Voltage Influence</b>	Maximum 0.02 % of span for each 1 % change of line voltage
Operating	
<b>Measuring Range</b>	<b><i>Triple Range Analyzer</i></b> Three ranges—Range 1 measures CO <sub>2</sub> in Air, Range 2 measures H <sub>2</sub> in CO <sub>2</sub> , and Range 3 measures H <sub>2</sub> in Air  <b><i>Single Range Analyzer</i></b> One range, as specified. For standard ranges, see Selection Guide Table in the Model Selection Guide.  <b><i>Explosion Proof Applications</i></b>  <b>WARNING</b> When measuring flammable gas mixture that contains oxygen, the maximum oxygen concentration must not exceed 21%.
<b>Output Ranges</b>	0-20 mA maximum load: 800 ohm 4-20 mA maximum load: 800 ohm

<p><b>0/4-20 mA Output</b></p>	<p><b>Triple Range Analyzer</b>  <i>Range 1: 0 to 100 % CO<sub>2</sub> in Air</i>  <i>Range 2: 0 to 100 % H<sub>2</sub> in CO<sub>2</sub></i>  <i>Range 3: 0 to 100 % H<sub>2</sub> in Air</i></p> <p><b>Single Range Analyzer</b>  <i>0/4 mA at low range limit</i>  <i>20 mA at high range limit</i></p>
<p><b>Alarm Outputs</b></p>	<p>One or two alarms are available; each uses an SPDT electromechanical relay.</p> <p><b>Alarm Relay Contacts Rating</b>  <i>Resistive Load: 5 amps @ 24 Vdc or 120 Vac or 240 Vac</i>  <i>Inductive Load: 50 VA</i></p>
<p><b>Outputs</b></p>	<p>One relay output for input sensor range control          One or two additional relay outputs for Alarm 1 and Alarm 2 (when 2nd current output not required)          One current output that represents value of PV of selected range.  <i>Indicator model (available with Triple Range only): 2nd current output (mutually exclusive with an alarm relay output)</i></p>
<p><b>Sample Requirements</b></p>	<p>Sample Temperature: -10 °C to +50 °C (14 °F to 122 °F)          Sample Flow: 0.2 to 4.2 cfh (100 cc/min to 2000 cc/min)          Sample Pressure: 37 mm Hg (20" H<sub>2</sub>O) minimum (with filter and flowmeter)          Sensor outlets must vent to atmospheric pressure.</p>
<p><b>Reference Gas Requirements</b></p>	<p><b>Triple Range Analyzer</b>          The triple range H<sub>2</sub> and CO<sub>2</sub> analyzer requires flowing air as the reference gas, 0.02 – 0.2cfh (10 – 100cc/min), 2 psig (13.79kPA) max.          Sensor outlets must vent to atmospheric pressure.</p> <p><b>Single Range Analyzer</b>          None required, except for ranges:          080000, 095000, 098000, 506000, and 516000; these require pure hydrogen reference gas flow          103000 and 510000; these require air reference flow          Gas Flow Rate: 0.02-0.2 cfh (10-100 cc/min), 2 psig (13.79kPA) max.          Sensor outlets must vent to atmospheric pressure.</p>
<p><b>Ambient Requirements</b></p>	<p><i>Relative Humidity:</i> 90 % maximum  <i>Temperature Range:</i> -10 °C to +50 °C (14 °F to 122 °F)  <i>Storage Temperature:</i> 70 °C maximum (158 °F)</p>
<p><b>Power Requirements</b></p>	<p><i>Control Unit only:</i> Universal supply 90 Vac to 264 Vac (consumption 18 VA maximum) or 24 Vac/dc (consumption 12 VA maximum); 50 Hz to 60 Hz</p>
<p><b>Materials Contacting Sample Gas</b></p>	<p>Sample contacts 316 stainless steel, Buna N, Teflon, glass and Viton</p>
<p><b>Connections</b></p>	<p><i>Sample inlet and outlet:</i> 1/4" OD tubing (compression fittings supplied)  <i>Reference gas inlet and outlet:</i> 1/4" OD tubing (compression fittings supplied)  <i>Electrical power inlet:</i> Opening for 1/2" conduit (control unit only)  <i>Sensing unit power inlet (24 Vdc from control unit):</i> 1/2" NPT (female conduit)</p>
<p><b>Communications (optional):</b></p>	<p><i>Link Characteristics:</i> Two-wire multi-drop Modbus RTU protocol, 15 drops maximum or up to 31 drops for shorter link length  <i>Distance:</i> 4000 feet maximum  <i>Baud Rate:</i> 2400 baud, 4800 baud, 9600 baud, or 19.2K baud selectable  <i>Data Format:</i> Floating point or integer  <i>Parity:</i> Selectable odd or even</p>

<p><b>Physical Specifications</b></p>	<p><b>Sensing Unit:</b>  <i>Weight:</i> 8.5 kg (18-3/4 lb.)  <i>Dimensions:</i> Approximately 150 mm x 150 mm x 325 mm (6 in. x 6 in. x 12-3/4 in.)</p> <p><b>Control Unit:</b>  <i>Weight:</i> 1.3 kg (3 lb.)  <i>Dimensions:</i> <i>Bezel:</i> 96 mm H x 96 mm W (3.78" H x 3.78" W)  <i>Case:</i> 92 mm H x 92 mm W x 192 mm D (3.62" H x 3.62" W x 7.55" D)</p>
<p><b>Standards – Sensing Unit</b></p>	<p><b>FM:</b> Class 1, Div. 1, Groups A,B,C,D  Class II, Div. 1, Groups E,F,G  Class III, Div.1  T6 @ T<sub>A</sub> = 50°C; Enclosure Type 4  Note: All conduits must be sealed within 18 inches</p> <p><b>CSA:</b> Class 1, Div. 1, Groups A,B,C,D  Class II, Div. 1, Groups E,F,G  Class III, Div.1  T6 @ T<sub>A</sub> = 50°C; Enclosure Type 4  Note: All conduits must be sealed within 18 inches</p> <p><b>NOTE:</b> Approvals standard on Triple Range units, optional on Single Range units.  See Model Selection Guide for details.</p>
<p><b>Standards – Control Unit</b></p>	<p>This product is in conformity with the protection requirements of the following European Council Directives: <b>73/23/EEC</b>, the Low Voltage Directive, and <b>89/336/EEC</b>, the EMC Directive. Conformity of this product with any other “CE Mark” Directive(s) shall not be assumed.</p> <p><i>Product Classification:</i> Class I: Permanently connected, panel-mounted Industrial Control Equipment with protective earthing (grounding). (EN61010-1).</p> <p><i>Enclosure Rating:</i> Panel-mounted equipment, IP 00. This controller must be panel-mounted. Terminals must be enclosed within the panel. Front panel IP 65 (IEC 529).</p> <p><i>Installation Category (Overvoltage Category):</i> Category II: Energy-consuming equipment supplied from the fixed installation, local level appliances, and Industrial Control Equipment. (EN61010-1)</p> <p><i>Pollution Degree:</i> Pollution Degree 2: Normally non-conductive pollution with occasional conductivity caused by condensation. (Ref. IEC 664-1)</p> <p><i>EMC Classification:</i> Group 1, Class A, ISM Equipment (EN55011, emissions), Industrial Equipment (EN50082-2, immunity)</p> <p><i>Method of EMC Assessment:</i> Technical File (TF)</p> <p><i>Declaration of Conformity:</i> 51309602-000</p>
<p><b>Miscellaneous</b></p>	<p><i>Analyzer temperature:</i> Sensing unit thermostated at 50 °C (122 °F)</p>

**Dimensions**

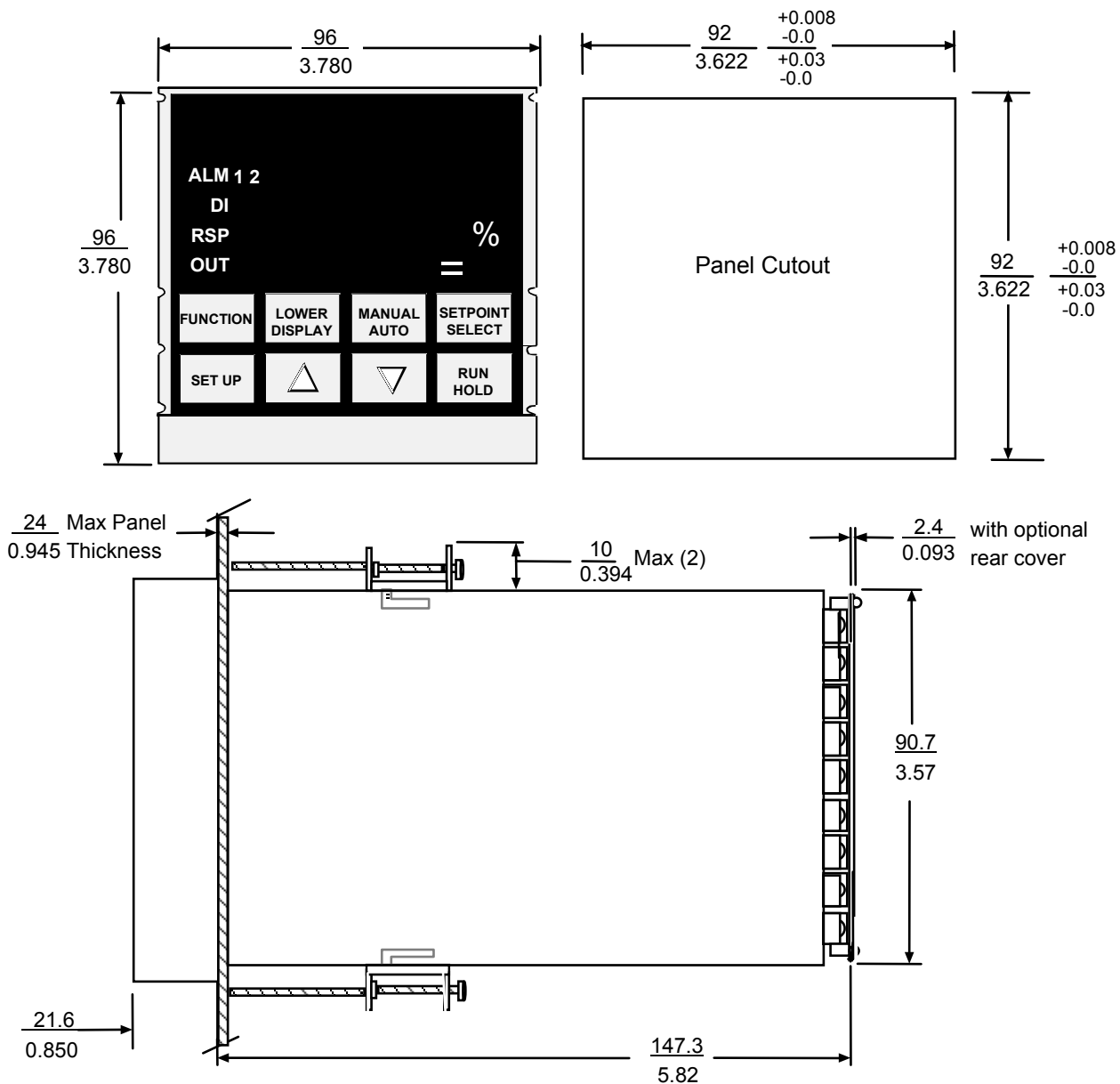
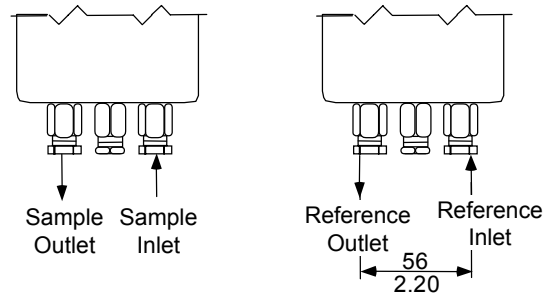
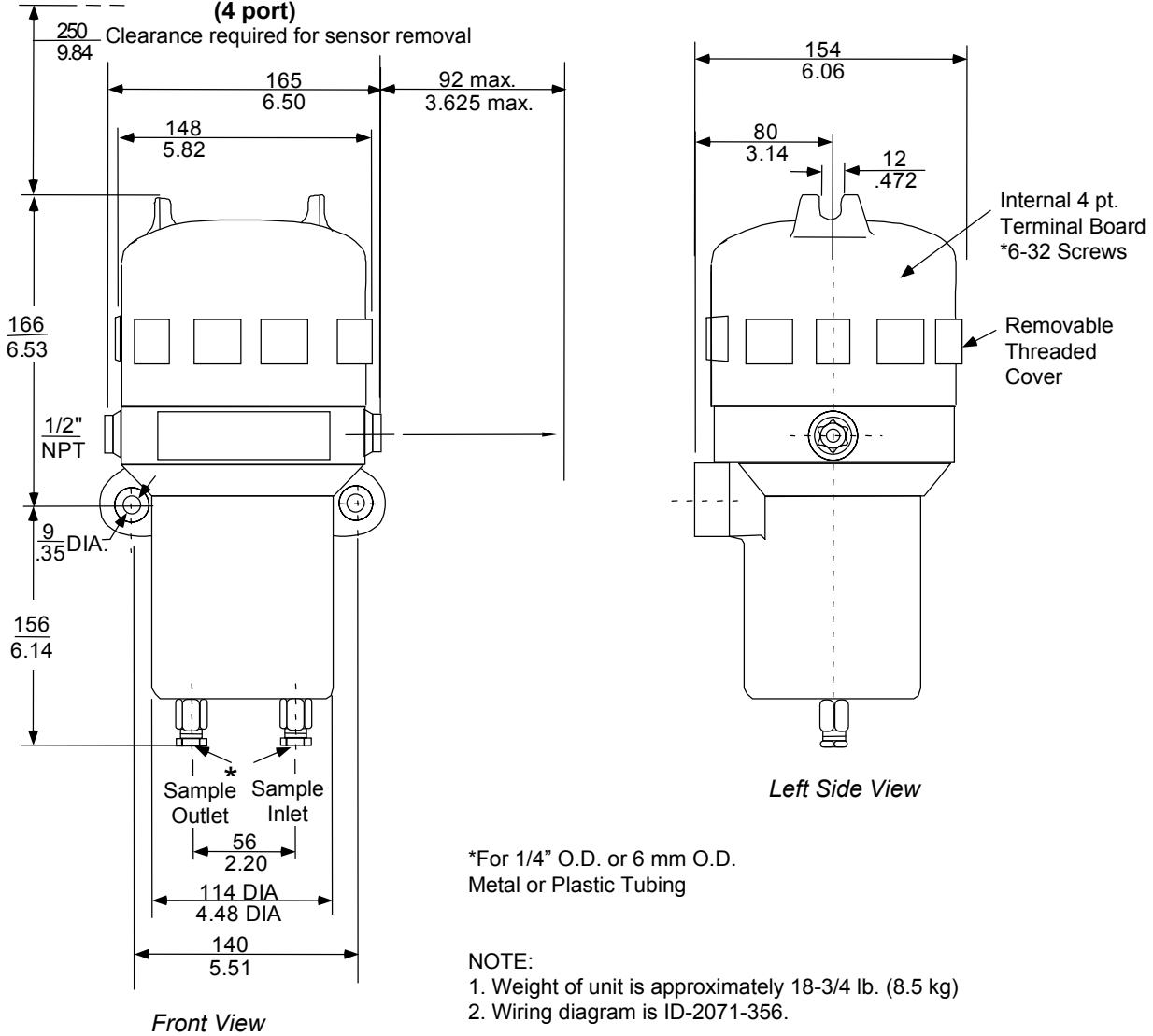

Figure 6—7866 Control Unit/Indicator Mounting Dimensions



**7866 Thermal Conductivity Analyzer  
(4 port)**



**Figure 7—7866 Sensing Unit Mounting Dimensions**

## WARRANTY/REMEDY

Honeywell warrants goods of its manufacture as being free of defective materials and faulty workmanship. Contact your local sales office for warranty information. If warranted goods are returned to Honeywell during the period of coverage, Honeywell will repair or replace without charge those items it finds defective. The foregoing is Buyer's sole remedy and is **in lieu of all other warranties, expressed or implied, including those of merchantability and fitness for a particular purpose**. Specifications may change without notice. The information we supply is believed to be accurate and reliable as of this printing. However, we assume no responsibility for its use.

While we provide application assistance personally, through our literature and the Honeywell web site, it is up to the customer to determine the suitability of the product in the application.

Distributor :



Tlf: 67150 250 Faks: 67 150 251

Mail: [post@instrumentteam.no](mailto:post@instrumentteam.no)

Web: [www.instrumentteam.no](http://www.instrumentteam.no)

---

**Honeywell**

**Industrial Measurement and Control**  
**1100 Virginia Drive**  
**Fort Washington, PA 19034**

70-82-03-46 4 06 Printed in USA

[www.honeywell.com/IMC](http://www.honeywell.com/IMC)