

DL423 DirectLine® Sensor Module for Conductivity Measurement

70-82-03-47

1/03

Page 1 of 8

Specification

Overview

DirectLine® DL423 for Conductivity measurement is a family of sensors released by Honeywell as part of a new generation of analytical measurement. The DirectLine sensor's unique architecture combines the latest in microelectronics technology with the proven performance of Honeywell conductivity cell, to provide unequaled savings during installation, start-up, operation, and maintenance.

The DirectLine® electronics module can mount integrally on the conductivity cell and provide a 4-20 mA dc output proportional to conductivity. The output of the DirectLine® sensor connects directly to any host monitor or control device that accepts standard 4-20 mA inputs and provides external loop power including:

- Honeywell UDC3300 1/4-DIN Controller
- UMC800 Controller
- PLCs with analog inputs
- DCS systems
- A host of recorder/controller products

For conductivity cell submersion or special mounting applications, the electronics module is also available in a remote-mounting configuration.

Description

The Honeywell DirectLine® architecture consists of an electronics module integral to the conductivity cell. This design eliminates the need and added cost of a separate analyzer or transmitter.

The electronics module is sealed in a plastic weatherproof, corrosion-resistant housing and is connected to the conductivity cell on one side and a 4-20 mA output cable on the other via waterproof connectors. This housing design allows this system to be used in harsh environments where moisture and dust is a problem.

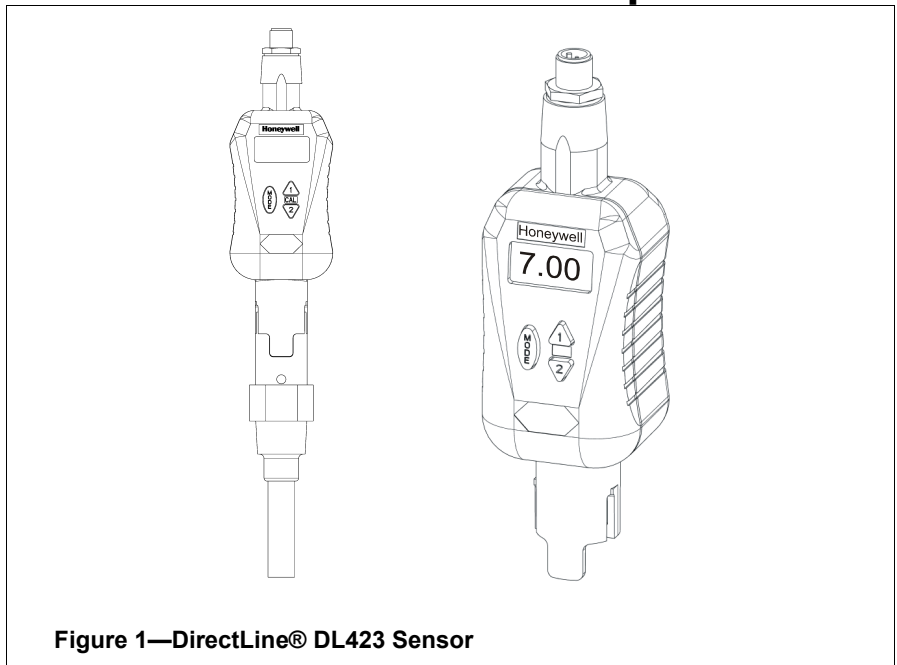

Figure 1—DirectLine® DL423 Sensor

Description, continued

For special mounting applications, the remote mounting option connects the electronics module to the conductivity cell via a cable. The electronics module is then mounted on a 2-inch pipe, wall, or DIN rail.

Features

- **Direct 4-20 mA output** eliminates need for dedicated analyzers or transmitters, simplifying installation, start-up, operation, and maintenance tasks. Installation costs are also reduced because standard cable can be used for additional cable distances.
- **Automatic upload of cell constant and cell calibration factor** from cell EEPROM reduces set-up time.
- **Integral electronics with local HMI** simplifies installation and shortens calibration times.
- **Modular plug-in construction** simplifies electrode replacements.
- **Local display and keypad** facilitates quick set-up, calibration, and operational activities.
- **½" NPT conduit connection** provides increased protection and noise immunity of output cable

Features, continued

- **Plug-in modular design** allows sensor to be safely removed and replaced without cycling power on the electronics module.
- **Electronics and sensor diagnostics** reduces troubleshooting times.
- **Trim value or 1-point solution calibration options** accommodates individual calibration techniques and reduces calibration time.
- **Temperature Sensor calibration options** for more accurate measurements.
- **Playing card-sized guide** facilitates simple, correct, and consistent calibration and configuration.
- **Watertight sensor connection** for reliability in submersion applications.
- **Global approvals** including:
 - CE Mark for industrial applications
 - UL General Purpose
 - CSA General Purpose
 - IP66 Type 4x Enclosure
 - FM Class I, Div. 1 (I.S.)
 - FM Class I, Div. 2 (non-incendive field wiring)

Electronics Module

Integral Electronics/Sensor Design

The DirectLine® electronics module is loop-powered by 16-42 Vdc source and will modulate its supply current from 4-20 mA, depending upon the conductivity value sensed by the cell. The output cable connects to the electronics module by a waterproof connector. The DirectLine® sensor's output cable connector is a standard M12 type receptacle. The M12 receptacle easily connects to a cord-set with an M12 connector or an M12 field wiring connector and customer-supplied cable.

The DL423 module quickly attaches to the cell and is easily locked-in-place for assured safety and reliability during operation. The cell can be removed from the module safely without disrupting power to the electronics.

Remote Mounting Applications

For special mounting applications, a remote electronics module option is available. The remote electronics module is mounted on a 2-inch pipe, wall, or DIN rail. The remote sensor cable directly connects the electronics module to the sensor with a submersible connector. The remote sensor cable is available in 20-ft. and is integral with the conductivity cell.

Operator Interface

The DirectLine® electronics module configuration, calibration, and maintenance functions are performed locally from three buttons and a 4-digit, 7-segment LCD display on the front side of the electronics module. The process variable, temperature (if available), and any error diagnostics are viewable from the local LCD display.

The following configuration functions are available.

- PV Type (Conductivity, Resistivity, TDS, and Concentration)
- TDS Factor
- Temperature Compensation Type
- Output configuration
- Noise suppression frequency selection

A playing card-sized guide comes with each DirectLine® sensor to guide you through a configuration or calibration quickly.

Online Diagnostics

The DirectLine® sensor continuously performs self-diagnostics on both the electronics and sensor. These prioritized self-diagnostics help to minimize the time and expense of troubleshooting during start-ups, maintenance, and calibrations.

If a problem arises with either the module electronics or the sensor, the software prioritizes the problem type and displays only the highest priority error diagnostic thus simplifying the troubleshooting process. Once the diagnostic is corrected, the error code disappears from the display.

Online Diagnostics, continued

If the electrode's temperature or process variable value goes out of operation range, the output current is driven to approximately 21.8 mA to inform the host device of a problem. Once the problem is corrected, the output current is returned back to normal and the error code disappears. Error codes are also used to indicate calibration failures.

Conductivity Cells

Honeywell's extensive line of conductivity cells are compatible with the DL423 Sensor Module. These cells are ruggedly constructed for reliable, continuous measurement of electrolytic conductivity up to 140°C and 250 psig.

The DL4000 line of conductivity cells are used with the DL423. An integral or remote configuration is available, depending on the process installation.

The integral conductivity cell design can be used for in-line and flow cell types of installations.

For immersion or ball valve mountings, a remote cell design is required. The remote cell design employs a cable integral to the cell that is connected to the DirectLine® Sensor Module.

The conductivity cell bodies are constructed of polyethersulfone (PES) for excellent corrosion resistance in a wide range of applications. Cell constants are available for applications ranging from ultrapure water to acid/base concentrations.

DL4000 Conductivity Cells have an EEPROM with the cell constant and cell calibration factor programmed into it. These values are automatically uploaded into the DirectLine® Sensor Module. This eliminates the need for the user to manually do this and reduces configuration errors.

Specifications

Display Ranges	Conductivity: 0 to 2000 μ S/cm, 0 to 20.00 mS/cm, 0 to 1000 mS/cm Resistivity: 0 to 20.00 M Ω -cm Total Dissolved Solids (TDS): 0 to 2000 ppm, 0 to 2000 ppb, 0 to 200ppt % Concentration: 0 to 20.00%
Displayed Temperature Range	-10 °C to +140 °C (14 °F to 284 °F)
Display Accuracy	Conductivity/Resistivity: Greater of +/- 2 counts or +/- 0.5% of reading Concentration: +/- 0.5% of reading Temperature: +/- 0.1°C from -10 to 99.9°C, +/- 1°C from 100 to 140 °C
Display Resolution	4 digits, floating decimal point
Process Temperature	-10 °C to +140 °C (14 °F to 284 °F)
Electronics Module Ambient Temperature	-20 °C to +85 °C (-4 °F to +185 °F)
Output Type	4-20 mA (2-wire loop powered)
Output Calibration	4-20 mA
Cell Constant and Cell Calibration Factor Input	Automatic from EEPROM in Conductivity Cell
Output (Loop) Cable Connection	M12 Type
Output (Loop) User Termination	Tinned leads on cord set or customer supplied cable
Cable Lengths Remote Sensor: Output:	20 feet (cable integral to conductivity cell) 20 feet or 50 feet
Power	16-42 Vdc, 23mA max <i>Maximum load resistance:</i> 250 ohms at 16 Vdc 600 ohms at 24 Vdc 1400 ohms at 42 Vdc
Local Display and Buttons	LCD 4-digit, 7-segment
Engineering Units (Labels)	μ S/cm, mS/cm, M Ω -cm, ppm TDS, ppb TDS, ppt TDS, %
Calibration Options	Cal Trim Factor, 1 Point Cal Solution
Solution Temperature Compensation	Acid (Cation/Ammonia), Salt (Neutral Salts), NaCl, HCl, NaOH, H ₂ SO ₄ , and None (for USP24 Conformance)
Diagnostics	Sensor and electronics
Case	Weatherproof, corrosion-resistant plastic housing
Approvals	CE Mark for Industrial Applications UL – General Purpose for Process Control CSA General Purpose for Process Control FM Intrinsically Safe, Class I, Div. 1, Groups A, B, C, D and Class I, Zone 0, AEx ia IIC FM Class I, Div. 2, Groups A, B, C, D and Class I, Zone 2, Groups IIC Enclosure: Type 4x, IP66
Remote Mounting	Pipe, Wall, or DIN Rail
Dimensions	H 123 mm (4.84") x W 48 mm (1.89") x D 46 mm (1.81")
Weight	Approximately 142 g (5.0 oz.)

Dimensions

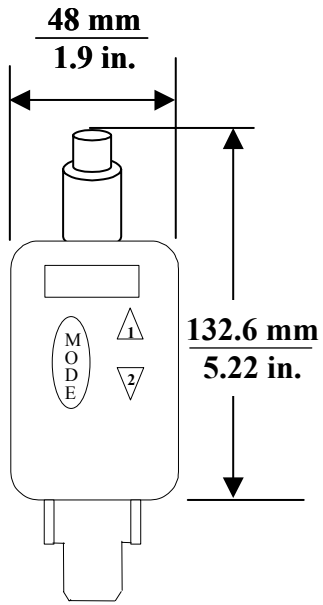

Front View

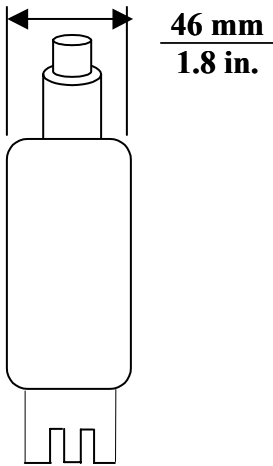

Side View

Figure 2—Dimensions

Mounting

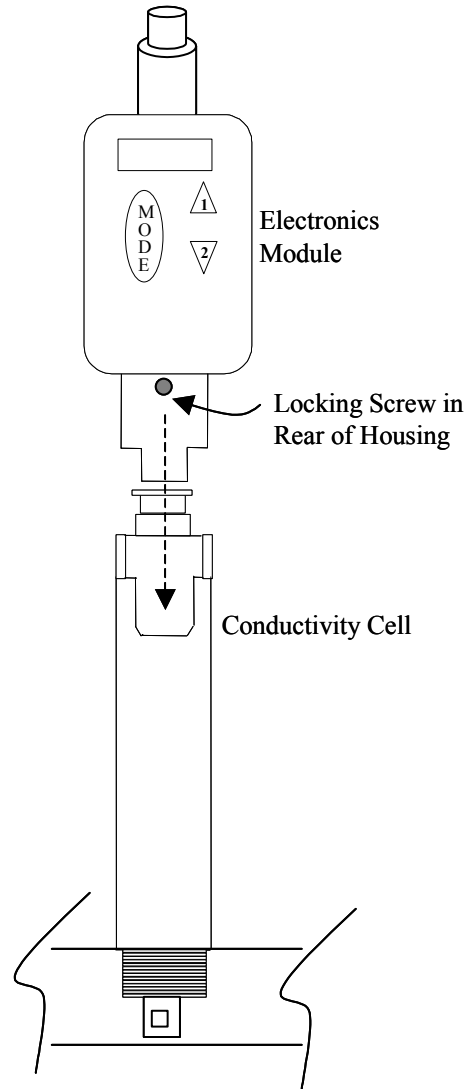

Figure 3—Integral Mounting

Mounting

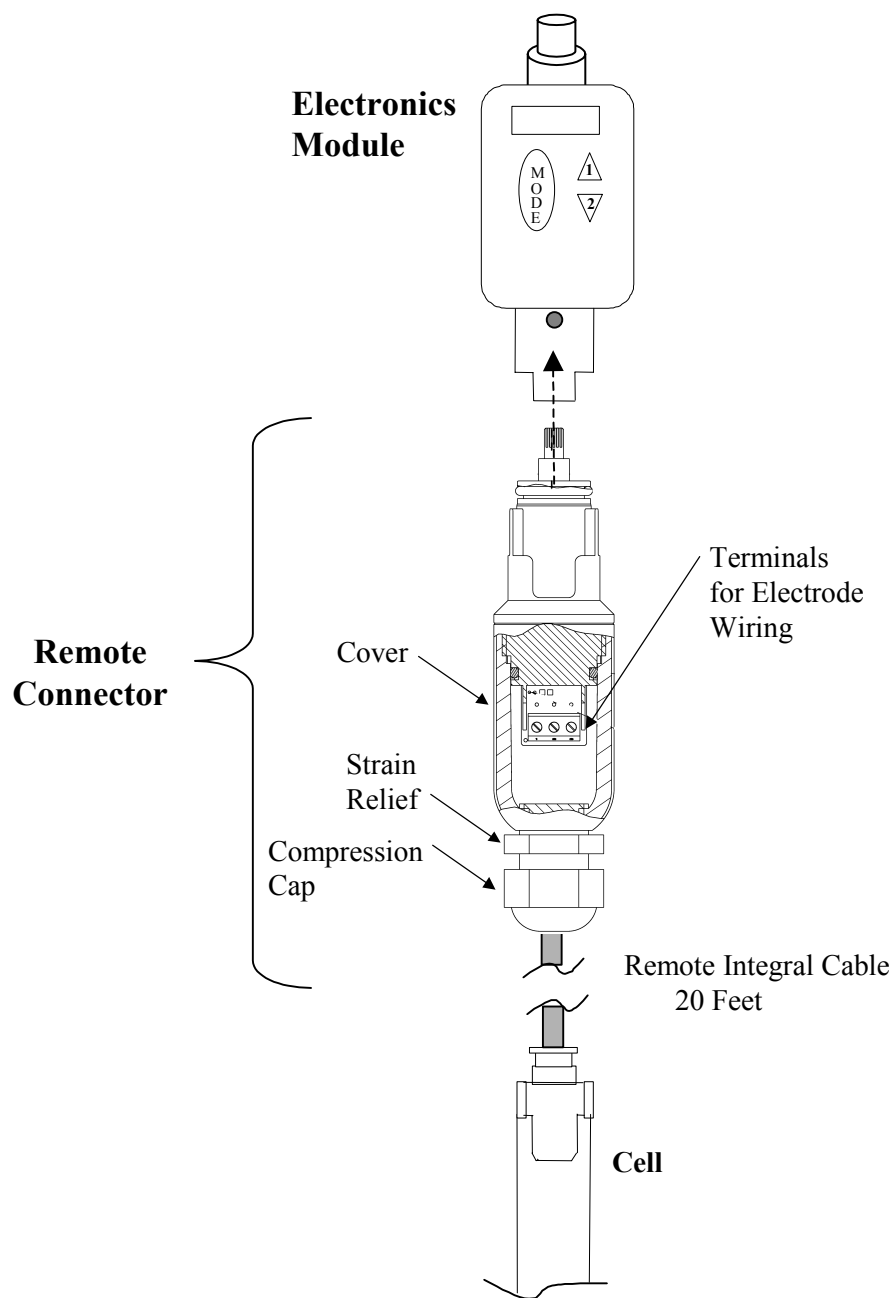
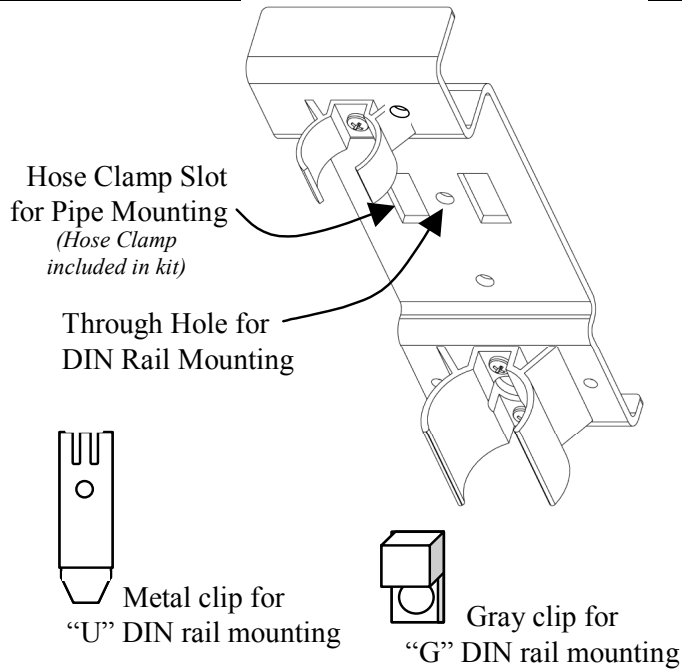

Figure 4—Remote Mounting

Mounting



Mounting Kit

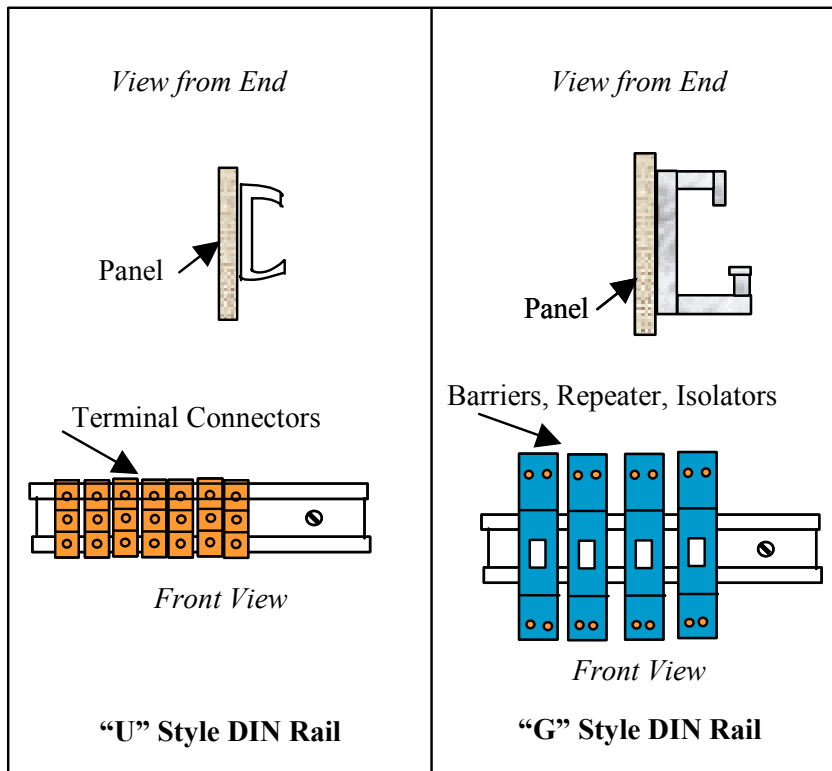

Figure 5—Remote Mounting Hardware

Model Selection Guide

Instructions

- Select the desired key number. The arrow to the right marks the selection available.
 - Make the desired selections from Tables I through IV using the column below the proper arrow. A dot (•) denotes availability.
- Key Number** I II III IV
 - - - -

Key Number - DirectLine® Sensor Electronics Module

(Specify electrodes/cells/probes separately)

		Selection	Availability			
pH	For use with Durafet II, Meredian II & HPW7000 pH electrodes	DL421	↓			
ORP	For use with ORP electrode.	DL422		↓		
Conductivity	For use with Contacting Conductivity Cells	DL423		↓		
DO - PPM	For use with Dissolved Oxygen ppm Probes	DL424			↓	
DO - PPB	For use with Dissolved Oxygen ppb Probes	DL425				↓

TABLE I - OUTPUT CABLE

		D	E	F
Output Cable for Integral or Remote Mounting	None (replacement module or customer supplied output cable)- Note 1	•	•	•
	Cordset - 6m (19.7 ft.) - includes connector and cable - Note 2	•	•	•
	Field Wiring Connector only - customer supplies cable only- Note 2	•	•	•

TABLE II - SENSOR CABLE/REMOTE CONNECTOR (between electronic module and electrode, sensor or probe)

		0	1	2	3	4	5	6
Integral Mounting	No cable or connector required	d	d	d	d	d		
Remote Mounting Cable - Durafet only	6,096m (20 ft.) of sensor cable - Durafet II Remote Mounting	e						
	15,24m (50 ft.) of sensor cable - Durafet II Remote Mounting	e						
Remote Mounting Connector (Cable is supplied with sensor or probe)	Remote Mounting Connector - Meredian II pH	e						
	Remote Mounting Connector - Meredian II ORP	e						
	Remote Mounting Connector - HPW7000	e						
	Remote Mounting Connector - Conductivity			e				
	Remote Mounting Connector - Dissolved Oxygen					e	e	

TABLE III - REMOTE MOUNTING OPTIONS

		A	B
Mounting Kit for Remote Mounting	None Integral unit - mounting not required	•	•
	2" (5,08 cm) Pipe mtg. bracket, wall mtg. & DIN Rail clip	•	•

TABLE IV - OPTIONS

		00	LT	SS	__00	__CC
Tagging	None	•	•	•	•	•
	Linen Customer ID Tag - 3 lines w/22 characters/line	•	•	•	•	•
	SS Customer ID Tag - 3 lines w/22 character/line	•	•	•	•	•
Certificates	None	•	•	•	•	•
	Calibration & Conformance	•	•	•	•	•

Notes:

- 1 Customer supplies cordset **or** cable with M12 connector. Suppliers & P/Ns include:

	Phoenix Contact	Turck
Cord-set	SAC-3P-5.0-PUR/M12FSSH Stainless	RKV4T-6/S618
M12 Field Wiring Connector	SACC-M12FS-4CON-PG7	B8141-0
Cable	2-wire twisted shielded pair	

- 2 Recommended cable is 2-wire twisted shielded pair

RESTRICTIONS

Restriction Letters	Available Only With		Not Available With	
	Table	Selection	Table	Selection
d	III	A		
e	III	B		

ORDERING INSTRUCTIONS:

- Part numbers are provided to facilitate Distributor Stock.
- Orders may be placed either by model selection or by part number.
- Part numbers are shown within the model selection tables to assist with compatibility information.
- Orders placed by model selection are systematically protected against incompatibility.
- Compatibility assessment is the responsibility of the purchaser for orders placed by part number.
- Items labeled as N/A are not available via the stocking program and must be ordered by model selection.

Warranty/Remedy

Honeywell warrants goods of its manufacture as being free of defective materials and faulty workmanship. Contact your local sales office for warranty information. If warranted goods are returned to Honeywell during the period of coverage, Honeywell will repair or replace without charge those items it finds defective. The foregoing is Buyer's sole remedy and is **in lieu of all other warranties, expressed or implied, including those of merchantability and fitness for a particular purpose**. Specifications may change without notice. The information we supply is believed to be accurate and reliable as of this printing. However, we assume no responsibility for its use.

While we provide application assistance personally, through our literature and the Honeywell web site, it is up to the customer to determine the suitability of the product in the application.

Distributor :



Tlf: 67150 250 Faks: 67 150 251

Mail: post@instrumentteam.no

Web: www.instrumentteam.no

For more information, contact Honeywell sales at 1-800-343-0228.

Honeywell

Industrial Measurement and Control

Honeywell

1100 Virginia Drive

Fort Washington, PA 19034