

UDA2182 Universal Dual Analyzer

Specification

Overview

The UDA2182 Universal Dual Analyzer is a new, economical, dual input analyzer addition to Honeywell's Smart Sensor product family.

The analyzer can accept single or dual inputs from Honeywell pH, ORP, contacting conductivity and dissolved oxygen sensors. For dual units the inputs can be ordered in any combination.

The UDA2182 monitors and controls Analytical process variables in applications such as:

- Power water quality control
- Wastewater influent & effluent
- Pure water preparation
- Food and Dairy
- Neutralization



Figure 1 - Front of UDA2182 Analyzer

Features

- Single or Dual input measurement
- Dual input in any combination of pH, ORP, contacting conductivity, or dissolved oxygen
- Versatile, backlit graphical display
- Infrared PC & Pocket PC configuration
- Optional input from Honeywell remote digital preamplifiers and Durafet Cap Adapters
- Isolated inputs and outputs
- CSA Type 4X (NEMA 4) enclosure
- Multilanguage prompts
- Two analog outputs standard plus one additional optional
- Two electromechanical relays standard plus two additional optional
- Real Time clock for Auto and History functions
- Auto Clean/Auto Cal functions
- Event History screens
- Calibration History information
- Easy access through hinged front door
- Full DIN Size
- Panel, wall or pipe mounting is available
- Easily Field Up-gradable
- Ethernet and RS485 Communications

Features, continued

The UDA2182 is a functional replacement for older Models 7082 and 9782 Analyzers. It will fit into the same panel cutout and has many of the same features and benefits of the former analyzers. Therefore it is compatible with existing pH and conductivity applications and installations.

The UDA2182 is UL Listed and CSA Certified. It is also CE Compliant.

The unique UDA2182 display is a graphical backlit LED. Two PV values along with their Unit of Measure can be displayed simultaneously. The process temperature of both PVs is also displayed. The versatile display will also display the analog output FS percent and the state of the relays.

Tagging and time or date information as well as status messages are available on the display and are easily configured by the user.

Configuration can be done with a PC through communication or with a Pocket PC, using the embedded infrared communication port. No need to get access to the back of the controller to download or upload a brand new configuration!

Analytical Inputs

The UDA2182 is a "Mix & Match" design. Analytical measurements of pH, conductivity and dissolved oxygen (ppm or ppb) can all be done in one analyzer. The unit can be used as a single input or dual input instrument – the user decides what measurements are included

The input boards are easily replaced and the addition of additional relays or an analog output is done with a single board. The "Mix –n– Match" design reduces inventory and increases flexibility. A user can purchase a basic unit and then add input and output boards as needed. The board changes are fast and easy with front, hinged access to the analyzer.

The wiring is easily accessible through the front and the boards can be pulled out to facilitate the wiring of sensor inputs.

Inputs are isolated so grounding problems associated with sensor input signals are minimized.

Outputs and Control

The following output types are available:

- Current Outputs (4-20 or 0-20 ma)
- Electromechanical Relays (5 amps)

The outputs are isolated and can be field allocated to the input PV, temperature, or computed value (conductivity)

Control Algorithms – Depending on the output algorithms specified, the controller can be configured for the following control algorithms:

- On-Off
- Current Adjusting Type (CAT)
- Pulse Frequency Type (PFT)
- Duration Adjusting Type (DAT)
- PID

Each control loop has as standard an auto-tuning feature using Honeywell's performance proven Accutune III tuning algorithm. A selectable "Fuzzy Logic" algorithm is also provided for each loop to suppress unwanted process setpoint overshoot.

Alarms

Two (or four) electromechanical alarm relays are field selectable for activating external equipment when preset alarm setpoints are reached based on the PV. Each alarm setpoint can be either a high or low alarm. The relays can also be assigned to temperature or diagnostics. The alarm hysteresis is configurable from 0 to 100% of range.

Operator Interface

Display – The UDA2182 has a versatile backlit, graphical LED display that is easy to read, even in the most difficult installations.

Multi-language prompts guide the operator step-by-step through the configuration process assuring quick and accurate entry of all configurable parameters. Nine languages are available via configuration: English, French, German, Spanish, Italian, Russian, Turkish, Polish and Czech.

Real Time Clock—A versatile clock set-up can be displayed on the tag name stripe and is used to initiate Auto Clean/Auto Cal functions and date/time stamp history logs.

Dedicated Keys—Provide direct access to Setup and Calibration to simplify and speed operation. Display key gives you access to advance function screens such as Control, Auto Cycling, USP26 and Calculated pH.

Miscellaneous

Moisture Protection – CSA Type 4X (NEMA 4X) rating for front and case permits use in applications where it may be subjected to moisture, dust, or hose-down conditions.

CE Mark – Conformity with 73/23/EEC, Low Voltage Directive and 89/336/EEC, the EMC Directive as a standard feature.

Approval Body Options – General Purpose CSA certification and UL listing and FM/CSA Class I, Div. 2 is standard.

Data Security – Keyboard security protects configuration and calibration data, accessed by a configurable 4-digit code. Nonvolatile EEPROM memory assures data integrity during loss of power

Calculated pH – High purity water pH can be calculated from Specific and Cation conductivities to be used as a check on in-line high purity water pH measurements.

Miscellaneous (cont'd)

Diagnostic/Failsafe Outputs – Continuous diagnostic routines detect failure modes, trigger a failsafe output value and identify the failure to minimize troubleshooting time.

High Noise Immunity –The controller is designed to provide reliable, error-free performance in industrial environments that often affect highly noise-sensitive digital equipment.

Quality/Support – The UDA2182 is covered by an 18-month warranty and backed up by a toll-free phone number for technical assistance (US Only).

Auto Buffer Calibration – for pH measurement the unit can be set up to recognize NIST, US, and Euro buffers and automatically select the standardize and slope values at the calibration temperature

Solution Temperature Compensation – For high purity water measurement the user can select pre-set compensations or configure custom values.

USP26 Alarm Capabilities – Relays can be configured to alarm on conductivity values as determined by the USP26 Standards

Computed Variables – For two-cell conductivity measurements, computed values of %Rejection/Passage, Difference, or Ratio can be displayed and assigned to the outputs or alarms. CO₂ concentration in ppm can be calculated from de-gassed conductivity measurement

Dissolved Oxygen –Auto-ranging of display and outputs with relays to indicate range, specialized probe bias diagnostics.

Auto Clean/Auto Cal –Built-in real time clock is used to set-up versatile cycles that can be used to initiate automatic sensor cleaning and then calibration.

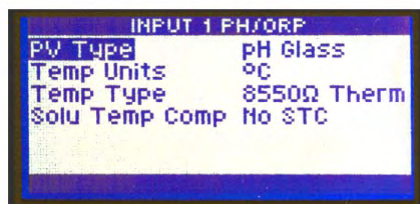
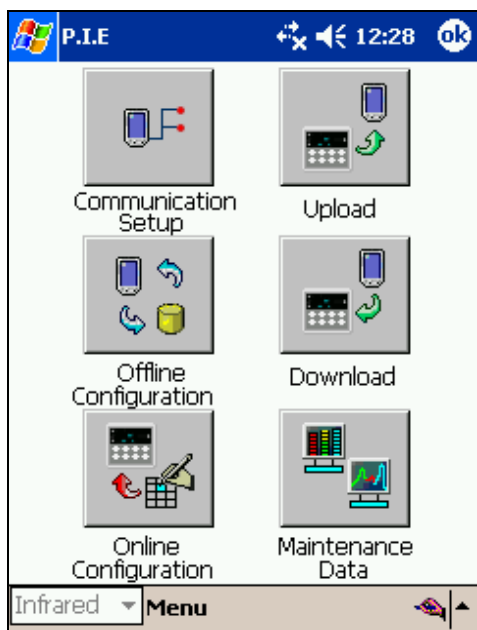

Figure 2 – UDA2182 Displays

PC & Pocket PC Software

Features

- Create configurations with intuitive software program running on a Pocket PC, a Desktop or a laptop computer.
- Create/edit configurations live; just connect software to analyzer via [IR](#), [RS485](#), or [Ethernet](#)
- Create/edit configurations offline and download to analyzer later via comm. port.
- Infrared port available on every UDA2182
- This software is available in English, Spanish, Italian, German, French, Russian, Turkish, Polish and Czech.



Screen capture of the configuration software running on a Pocket PC

Communications

Infrared

The infrared connection provides a non-intrusive wireless connection with the instrument and maintains NEMA4X integrity.

No need to get access to the back of the analyzer to communicate with the instrument, no need to take your screw driver to wire the communication cable, no wiring mistake possible! You can now duplicate an instrument's configuration, upload or download a new configuration in a matter of seconds, just by pointing your Pocket PC in the direction of the instrument.

Aim & Upload! It takes less than 2 seconds to upload a configuration from an instrument! You can then save the configuration file onto your PC or pocket PC for review, modification or archiving.

Furthermore, this software also gives you important maintenance information on the analyzer: instantly, get information on the current operating parameters, digital inputs and alarm status, identify internal or analog input problems.

Question: What if I have several analyzers on the same panel? How can I be sure I am communicating with the correct one?

Answer: The Infrared port is normally "off". You activate the infrared port on a particular analyzer by pressing any key. You can now communicate with the analyzer. If no communications are received for 2 minutes, the IR port will be shut down again.



Communications, *continued*

Communications Card (Optional)

The Communications card provides one Serial Port (RS485) and one Ethernet Port.

Serial port provides

- RS422/RS485 multi-drop
- 2400 to 115,200 programmable baud rate
- Modbus RTU protocol to read signals including PV, Temperature, Alarm Status, outputs, relay status, etc.
- Read/write four analog and four digital variables (**Note 1**)

Ethernet port provides:

- Up to 5 Modbus simultaneous TCP connections
- Ethernet parameters are configured via the front-panel or web pages.
- Web server with up to 10 clients simultaneously
- Web pages (**Note 2**) setup the Ethernet port settings and monitor readings, alarms, statuses, events
- Multi-language Email to send alarm status changes. Alarm notification to eight email addresses. These must be configured using web pages signed in as the administrator.
- **DHCP:** (*Dynamic Host Configuration Protocol*) selectable via web page or front-panel
- Firmware upgrade to Main CPU board
- Firmware upgrade to Communications card

Communications, *continued*

Note 1

There are four analog and four digital variables. These variables can be read and written remotely using Modbus function codes.

Variables will appear as a selection for various parameters:

- *Analog variables* can be an alarm source, analog relay source, current output source, monitor source, math source, auxiliary switch source, PID TRV, and PID remote setpoint.
- *Digital variables* can be an alarm disable, remote setpoint select, Tune Set2 select, digital relay source, logic-in source, auxiliary switch select, PID TRC select, PID RSP select, and auto cycle start source.

Note 2

Web pages provide the following:

- Multiple language support
- "Guest" accessibility for read-only permission
- "Admin" accessibility for read and write permission
- Readings of Inputs, Outputs, and Relay Outputs
- Status of Inputs, Outputs, and Alarms.
- Readings and Status of optional parameters (control, pharma, and auto-cycle)
- List of last twelve events
- Network configuration including IP address, subnet mask, gateway etc.
- Email configuration for alarm event notification

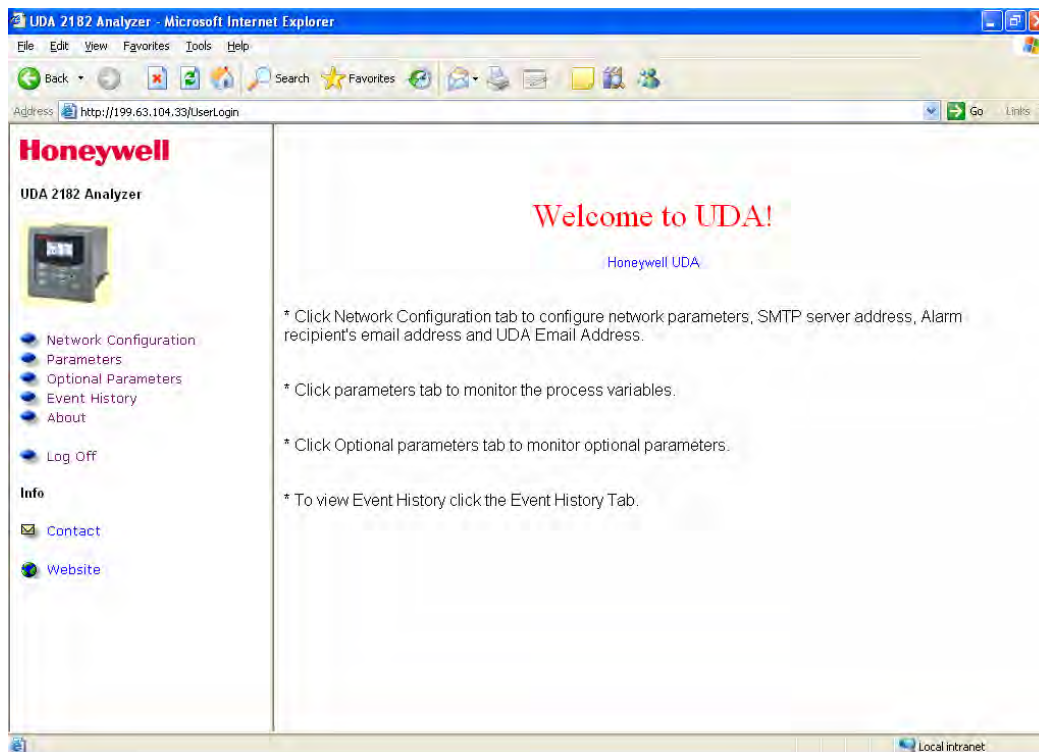

Screen capture of the UDA2182 Analyzer Web page

Specifications

UDA2182 Dual Input Analyzer	
Display	Graphical LCD with white LED Backlight Viewing Area: 66.8 mm (W) X 35.5 mm (H) Dot Pixels: 128 (W) X 64 (H)
Display Ranges	<p><i>pH:</i> 0-14 pH Temperature: -10 to 110°C (14 to 230°F)</p> <p><i>ORP:</i> -1600 to +1600 mV</p> <p><i>Conductivity:</i> 0.01 Cell: 0-2 uS/cm displayable to 200 uS/cm; 0-0.2 mS/cm; 0-2,000 ppb TDS; 0-200 ppm TDS 0.1 Cell: 0-20 uS/cm displayable to 2000 uS/cm; 0-2 mS/cm, 0-2,000 ppb TDS; 0-2,000 ppm TDS, 1.0 Cell: 0-200 uS/cm displayable to 20,000 uS/cm; 0-20 mS/cm; 0-200 ppm TDS; 0-20 ppt TDS 10 Cell: 0-2,000 uS/cm displayable to 99999 uS/cm; 0-200 mS/cm; 0-2,000 ppm TDS; 0-200 ppt TDS 25 Cell: 0-20,000 uS/cm displayable to 99999 uS/cm; 0-500 mS/cm; 0-10% Concentration displayable to 20% 50 Cell: 0-20,000 uS/cm displayable to 99999 uS/cm; 0-1,000 mS/cm; 0-20% Concentration Temperature: 0 to + 140°C (32 to 284°F)</p> <p><i>Dissolved Oxygen:</i> 0 - 200 ppm 0 - 20 ppb 0 -200 ppb 0 - 2000ppb Temperature: 2 - 60°C (35.6 - 104°F), must not freeze</p>
Keypad	10 Button Membrane Switch w/Directional Functionality UV/Solvent/Abrasion Resistant
Case Material	GE Valox [®] 357 (un-reinforced thermoplastic polyester)
Performances (Under reference operating conditions)	<p>Accuracy: 0.5% of reading Output Accuracy: +/- 0.01 mA Drift: Negligible Repeatability: 0.05% Temperature Accuracy: pH and Conductivity Thermistor: +/- 0.1°C from -10 to 100° C, +/- 1.0° C from 101° to 140° C pH 1000 ohm RTD: +/- 0.4° C D.O. Thermistor: +/- 0.1° C from +2 to 60° C Reference Operating Conditions: 25 +/- 1° C; 10-40% RH; 120 or 240 Vac</p>
Operating Conditions	<p>Ambient Temperature Operating: 0 to 60°C (32 to 140°F) Storage: -30 to 70°C (-22 to 158°F) RH: 5 to 90% max. Non-condensing up to 40°C (104°F). For higher temperatures the RH specification is derated to maintain constant moisture content. Vibration: 5-15 Hz disp 8 mm pk to pk 15-200 Hz accel 2 G</p>
Standard Analog Output	Two 0-20 or 4-20 mAdc, 750 ohms max., isolated from inputs, ground, and each other, independently field-assignable to any parameters and ranges. Proportional to user-set output range(s) of selected parameter(s).
Optional Analog Output	One 0-20 or 4-20 mAdc, 750 ohms max., isolated from inputs, ground, and each other. Independently field-assignable to any parameters and ranges.

UDA2182 Dual Input Analyzer	
Control Loop/Outputs (Optional)	Control Loops: 2 standard (one for each PV); current, pulse frequency, or time proportional Control Loop Types: PID, Duplex, On/Off Auto-tuning: Accutune II, fuzzy logic overshoot suppression, applicable to both control loops
Standard Alarm/ Control Relays	Two SPDT (Form "C") Relays Resistive Load Rating: 4A, 120/240 Vac
Optional Additional Alarm/Control Relays	Two SPDT (Form "C") Relays Resistive Load Rating: 4A, 120/240 Vac
Alarm/Control Settings	Alarm/on-off control delay: 0-100 seconds. Alarm/on-off control deadbands: individually set, from 1 count to full scale for pH, ORP, and temperature. On/off cycle period: 0 to 1000 seconds. On/off percent "on" time: 0 to 100%, 1% resolution. Setpoint and proportional band limit ranges: ± 19.99 pH, ± 1999 mV, -10 to 130°C, 1 count resolution. DAT cycle period: 1 to 1999 seconds. PFT maximum frequency: 1 to 200 pulses/minute. PFT pulse width: 50 ms, compatible with electronic pulse-type metering pumps.
Remote Preamplifier Input Option	Optional input card to accept input signal from Honeywell digital preamplifiers: Meridian II – 31075707 and 31022283 Durafet – 31079288 and Cap Adapter cables
pH Temperature Compensation	Conventional compensation for changing electrode output (Nernst response), plus selectable solution temperature compensation for high-purity water.
Calculated pH from Differential Conductivity	User selectable when unit has two Conductivity inputs. Used when ammonia or aminea is the water treatment chemical.
Auto Buffer Recognition (pH)	User Selectable Available Buffer Series: NIST, US, and Euro
Conductivity Compensations	NaCl, HCl, H ₂ SO ₄ , PO ₄ , NaOH, NH ₃ , Morpholine, Pure Water, Custom (User Selectable)
Dissolved Oxygen Measurement	Max flowrate (probe): 950 ml/min with flow chamber; no dependence on stirring or flowrate Atmospheric pressure: 500-800 mm Hg with internal sensor, for calibration Calibration with either Air or Sample
Auto Clean/ Auto Cal Function	Real time clock is used to set-up cycles to initiate a cleaning and calibration sequence. Cycle Set-up is user configurable.
Event History Screen	Event history screen stores 256 events with a description of the event and a Date/time stamp.
Calibration History Screen	Calibration history screen stores information on 128 calibration events with a date/time stamp.
Power Requirements	90 -264 Vac, 47-63 Hz, 15 VA . Memory retained by E ² PROM when power is off.
Wireless Interface	Type: Infrared (IR) Length of Link: 0 –1 M, 0 –15° Offset Baud Rate: 9600 Data Format: Modbus Protocol
RS422/RS485 Modbus RTU Slave Communications Interface (Optional)	<i>Baud Rate:</i> 2400, 4800, 9600, 19200, 38400, 57600, or 115200 selectable <i>Data Format:</i> IEEE floating point and 32-bit integer. Word-Swap configurable. <i>Length of Link:</i> 2000 ft (600 m) max. with Belden 9271 Twinax Cable and 120 ohm termination resistors 4000 ft (1200 m) max. with Belden 8227 Twinax Cable and 100 ohm termination resistors <i>Link Characteristics:</i> Two-wire (half-duplex), multi-drop Modbus RTU protocol, 15 drops maximum or up to 31 drops for shorter link length. Modbus RTU slave: Provides monitoring of inputs outputs, statuses, alarms, and variables. Provides writing of variables for remotely modifying parameter settings

UDA2182 Dual Input Analyzer	
Ethernet TCP/IP Communications Interface (Optional)	<p><i>Type:</i> 10 or 100 BaseT; auto-speed and auto-polarity sensing <i>Length of Link:</i> 330 ft. (100 m) maximum. Use Shielded twisted-pair, Category 5 (STP CAT5) Ethernet cable. <i>Link Characteristics:</i> Four-wire plus shield, single drop, five hops maximum <i>IP Address:</i> IP Address is 192.168.1.254 as shipped from the factory <i>Recommended network configuration:</i> Use Switch rather than Hub in order to maximize UDA Ethernet performance <i>Configuration:</i> Ethernet parameters are configured via the front-panel or web pages. <i>Modbus TCP/IP:</i> Five simultaneous socket connections provide monitoring of inputs outputs, statuses, alarms, and variables. Provides writing of variables for remotely modifying parameter settings. <i>Modbus TCP/IP Data Format:</i> IEEE floating point and 32-bit integer. Word Swap configurable. <i>Web server:</i> multiple client support <i>Web pages:</i> monitoring inputs, outputs, statuses, alarms, and events <i>Multi-language Email:</i> Alarm notification to eight email addresses. These must be configured using web pages signed in as the administrator. <i>DHCP:</i> (Dynamic Host Configuration Protocol) selectable via web page or front-panel</p>
Safety Compliance	<p>UL/CSA General Purpose FM Approval for Class I, Div 2.</p>
CE Compliance	<p>CE Conformity (Europe): CE Mark on all models signifies compliance to EMC Directive 84/336/EEC and LVD Directive 73/23/EEC. EMC Classification: Group 1, Class A, ISM Equipment Method of Assessment: Technical File; EN61326, EN61010-1 Declaration of Conformity: 51453667</p>
Installation Rating	<p>Installation Category (Overvoltage Category): Category II Pollution Degree 2 Altitude: 2000 m</p>
Case Dimensions	<p>156 mm X 156 mm X 150 mm (6.14" X 6.14" X 5.91") Panel cutout: 138.5 mm X 138.5 mm (5.45" X 5.45") Panel thickness: 1.52 mm (0.06") min, 9.5 mm (0.38") max</p>
Enclosure rating	<p>CSA Type 4X (NEMA 4X)</p>
Weight	<p>Approx 3 lbs (6.6kg)</p>
Mounting	<p>Panel mounting-hardware supplied. Optional Wall and 1" to 2" pipe mounting. Select option appropriate in Model Number.</p>

Dimensions

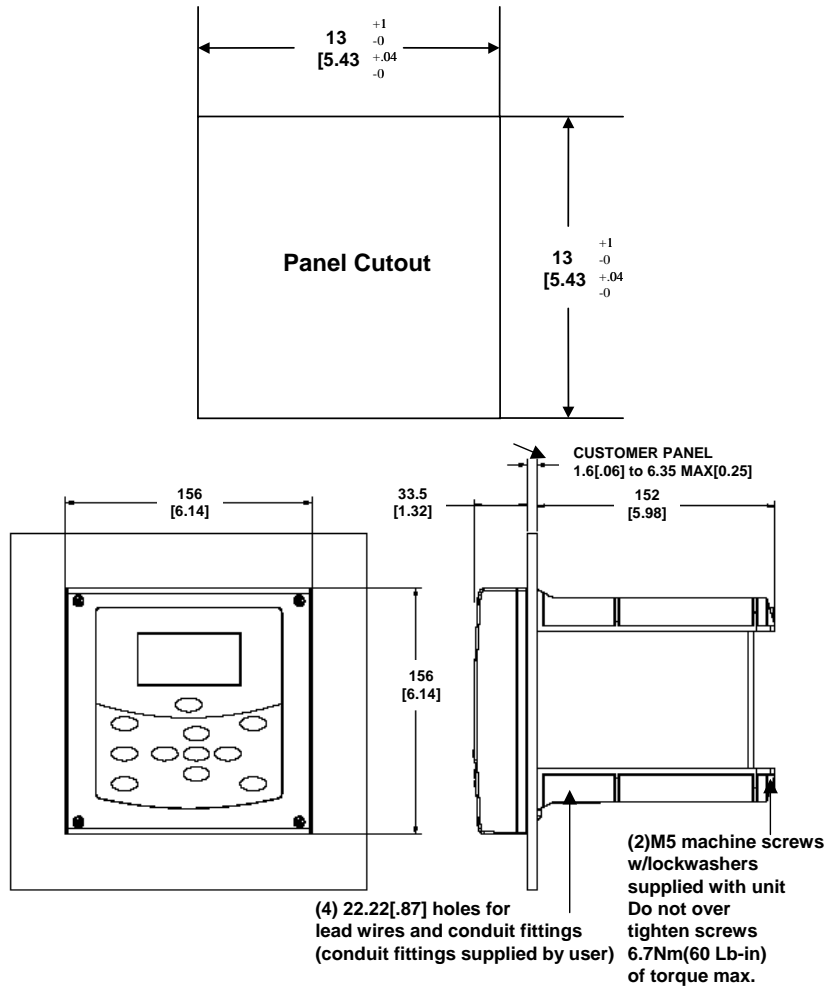

Figure 3—Cutout and Panel Mount Dimensions

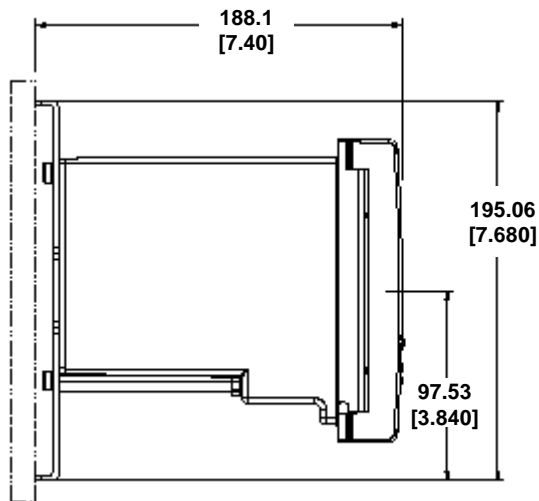

Figure 4 – Wall/Pipe Mounting Dimensions

Warranty/Remedy

Honeywell warrants goods of its manufacture as being free of defective materials and faulty workmanship. Contact your local sales office for warranty information. If warranted goods are returned to Honeywell during the period of coverage, Honeywell will repair or replace without charge those items it finds defective. The foregoing is Buyer's sole remedy and is **in lieu of all other warranties, expressed or implied, including those of merchantability and fitness for a particular purpose**. Specifications may change without notice. The information we supply is believed to be accurate and reliable as of this printing. However, we assume no responsibility for its use.

While we provide application assistance personally, through our literature and the Honeywell web site, it is up to the customer to determine the suitability of the product in the application.



Tlf: 67150 250 Faks: 67 150 251

Mail: post@instrumentteam.no

Web: www.instrumentteam.no

Honeywell

Honeywell Field Solutions

2500 W. Union Hill Drive
Phoenix, Arizona 85027
Tel: 877.466.3993 or 602.313.6665

www.honeywell.com/ps

70-82-03-54
January 2009
© 2009 Honeywell International Inc.