

## DCP 300 Digital Controller Programmer

EN01-6065 12/99

PRODUCT SPECIFICATION SHEET

### Function

The DCP300 is a high-function digital controller programmer supporting up to 19 program profiles with up to 30 segments per profile. A universal input accepts thermocouple signals, resistance temperature detector (RTD) signals, DC voltages and DC currents. DCP301 is a single channel (1 input) version. DCP302 is a dual channel model with 2 inputs and 2 loops. A temperature and relative humidity calculation model which controls temperature and relative humidity is selectable on DCP302.

The DCP300 supports extensive digital I/O functions including 3 event outputs, 5 time events (optional) and 12 external switch inputs (8 optional). RS485 communications and up to 2 auxiliary outputs can also be added on as an option. DCP302 has only 1 auxiliary output available.

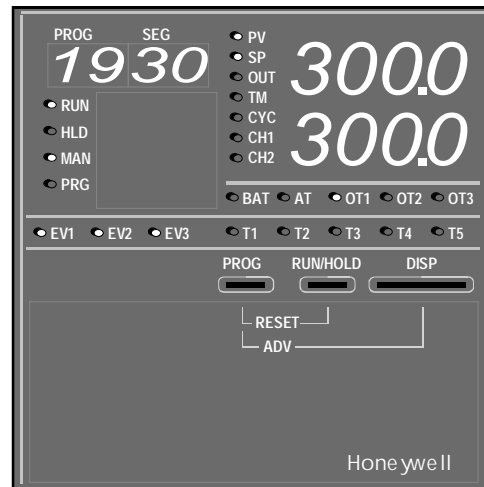
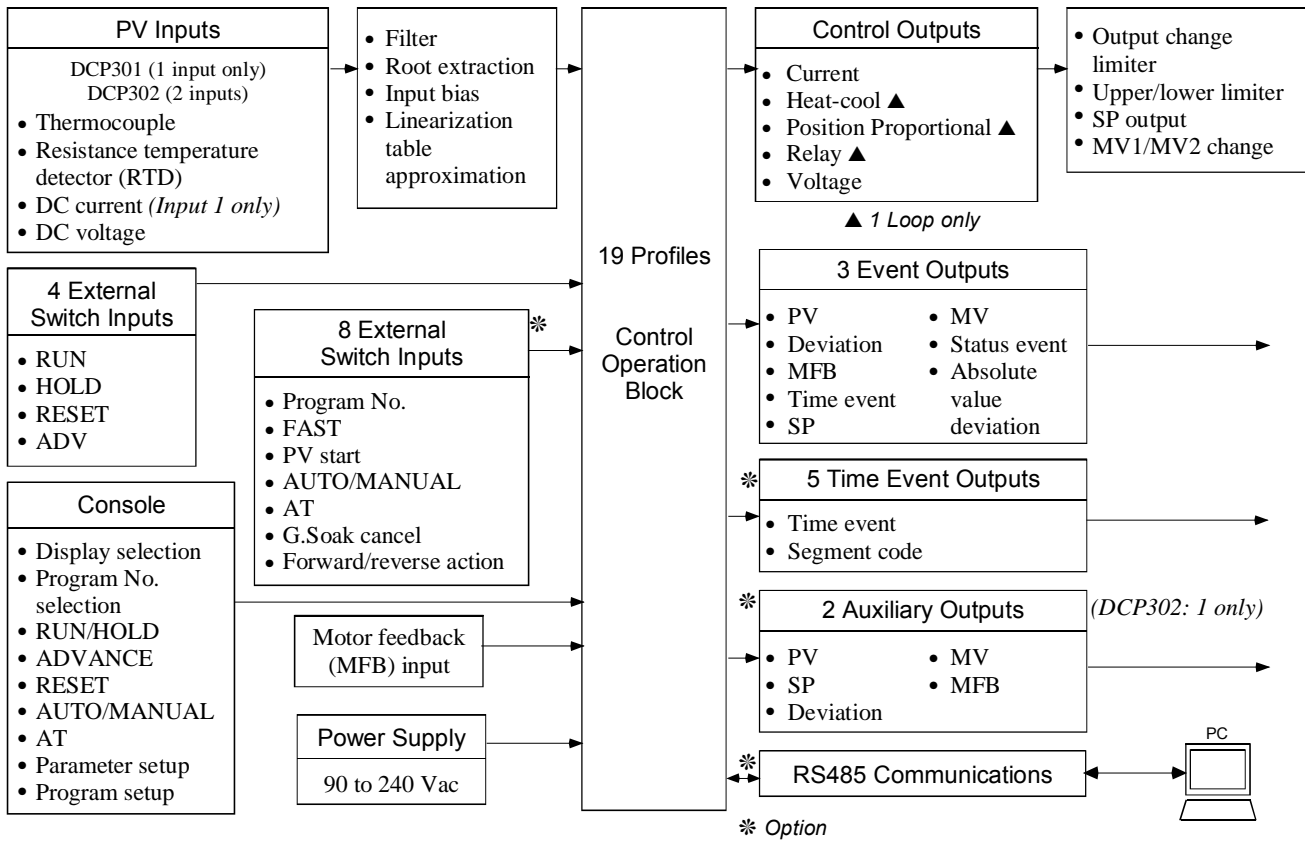

Figure 1—The DCP300 Digital Controller Programmer

### Features

- Input 1 Accuracy =  $\pm 0.1\%$  FS (Input 2 Accuracy =  $\pm 0.2\%$  FS). High-speed sampling time of 0.1 seconds.
- Any input type can be selected by key operation.
- A maximum of 19 program profiles can be stored and up to 30 segments can be programmed to each profile.
- Three event outputs for PV, deviation, controller mode or other states are standard.
- Twelve external switch inputs (eight optional) allow remote selection of program numbers or operation.
- Up to eight frequently changed parameter setups can be registered to the PARA key.
- Universal AC power supply within range of 90 to 264 Vac, 50/60 Hz.
- CE mark compliant applicable standards: EN61010-1, EN50081-2, EN50082-2
- Wide range of optional functions enables use in an extensive range of applications:
  - 5 time event outputs
  - 8 digital inputs
  - 2 auxiliary outputs on DCP301; 1 auxiliary output on DCP302.
  - Communications: RS485 ASCII
- Relative Humidity model available on DCP302.

**Basic Function Blocks of DCP301/302**



**Specifications**

Program	
Number of Programs	19 maximum
Number of Segments	30 per program maximum
Segment Setting System	RAMP-X system: Set by setpoints (SP1, SP2) and time.
Segment Time	0 to 99 hours 59 minutes; or 0 to 99 minutes 59 seconds (time unit selectable)
Basic Time Accuracy	±0.01% (0.1 second delay when segment time setting is 0)
Events (3)	Sets operating point.
Time Events (5)	Sets ON and OFF times.
PID Set Number (each channel)	Sets 0 to 8. (Set 0 for continuation of previous segment.) (Set 0 to 4 on heat/cool models.)
G.Soak (each channel)	Sets G.Soak width 0 to 1000U.
PV Start	Sets program ON/OFF and channel.
Cycle	Sets program count 0 to 9999.
Pattern Link	Sets program number 0 to 19 (0: no link).
Tag	Sets 8 alphanumerics for each program (not displayed on controller).

## Specifications, continued

Input 1	
<b>Input Type</b>	Thermocouple, resistance temperature detector, DC voltage, DC current multi-range (Table 1)
<b>Input Readout Accuracy</b>	<p>±0.1% FS ±1U (varies according to standard conditions, display value conversion and range)</p> <ul style="list-style-type: none"> <li>• At –100°C maximum of K and T thermocouples: ±1°C ±1U</li> <li>• At 260°C maximum of B thermocouple: ±4.0% FS ±1U  At 260 to 800°C: ±0.4% FS ±1U  At 800 to 1800°C: ±0.2% FS ±1U</li> <li>• At 100°C maximum of R and S thermocouples: ±0.2% FS ±1U  At 100 to 1600°C: ±0.15% FS ±1U</li> <li>• At 300°C maximum of PR40-20 thermocouple: ±2.5% FS ±1U  At 300 to 800°C: ±1.5% FS ±1U  At 800 to 1900°C: ±0.5% FS ±1U</li> <li>• Golden iron chromel thermocouple: ±1.5K ±1U</li> <li>• F01, F33, F38, P01, P33 and P38 ranges by resistance thermometer detector input: ±0.15% ±1U</li> <li>• At 0 to 10 mV range: ±0.15% FS ±1U</li> <li>• At –100°C maximum of DIN U thermocouple: ±2°C ±1U  At –100 to 0°C: ±1°C ±1U</li> <li>• At –100°C maximum of DIN L thermocouple: ±1.5°C ±1U</li> </ul>
<b>Input Sampling Cycle</b>	0.1 seconds
<b>Input Bias Current</b>	<i>Thermocouple, DC voltage input:</i> ±1.3 µA maximum (at peak value, under standard conditions). At 1 V minimum range: –3 µA maximum.
<b>Input Impedance</b>	<i>DC current input:</i> 50Ω ±10% (under operating conditions)
<b>Measuring Current</b>	<i>RTD input:</i> 1.04 mA ±0.02 mA, current flow from terminal A (under operating conditions)
<b>Influence of Wiring Resistance</b>	<p><i>Thermocouple, DC voltage input:</i> Changes in readout value at wiring resistance of 250Ω at both ends are as follows by input conversion:</p> <ul style="list-style-type: none"> <li>• 0 to 10 mV, –10 to +10 mV: Within 35 µV</li> <li>• 0 to 100 mV: Within 60 µV</li> <li>• Other: Within 750 µV</li> </ul> <p><i>RTD input:</i> ±0.01% FS/Ω maximum in wiring resistance range 0 to 10Ω. Range of F01, F33, F38, P01, P33, and P38: ±0.02% FS/Ω maximum.</p>
<b>RTD Input Allowable Wiring Resistance</b>	<ul style="list-style-type: none"> <li>• Allowable wiring resistance is 85Ω maximum (Including Zener barrier resistance. When Zener barrier is used, this applies only to ranges other than F01, F33, F38, P01, P33, and P38. Note that site adjustment is required.)</li> <li>• Allowing wiring resistance is 10Ω maximum (This applies to ranges F01, F33, F38, P01, P33, and P38. Note that the Zener barrier cannot be used.)</li> </ul>
<b>Allowable Parallel Resistance</b>	<i>Thermocouple disconnection detection allowable parallel resistance:</i> 1 MΩ minimum
<b>Maximum Allowable Input</b>	<i>Thermocouple, dc voltage input:</i> –5 to +15 Vdc <i>DC current input:</i> 50 mA dc; 2.5 Vdc
<b>Burnout</b>	Upscale and downscale can be internally selected. (DC current input and DC voltage input ranges of 1V or more are only downscaled.)

## Specifications, continued

Input 1, continued	
Over-range Detection Threshold	110% FS minimum: Upscale –10% FS maximum: Downscale (Note that F50 range is not downscaled. Lower readout limit of B18 range is 20°C.)
Cold Junction Compensation Accuracy	±0.5°C (under standard conditions)
Influence of Ambient Temperature on Cold Junction Compensation	±0.2°C (in range 0 to 50°C)
Cold Junction Compensation System	Internal/external (0°C only) compensation selectable
Scaling	–1999 to +9999U (Settable by DC voltage and DC current. Reverse scaling and decimal point repositioning possible.)
Square Root Extraction	Dropout 0.1 to 10.0%. Possible by DC current and voltage ranges.
Linearization Table Approximation	12 (both line ends fixed, 11 points variable)
Input Bias	–1000 to +1000U variable
Digital Filter	0.0 to 120.0 seconds variable (filter OFF at 0.0)
Input 2 (DCP302 only)	
Input Type	Thermocouple, resistance temperature detector, DC voltage, multi-range (Table 2)
Input Readout Accuracy	±0.2% FS ±1U (varies according to standard conditions, display value conversion)
Input Sampling Cycle	0.1 seconds
Input Bias Current	<i>Thermocouple</i> : ±2.0 µA maximum (under standard conditions). <i>DC voltage input</i> : ±5 µA maximum (under standard conditions)
Measuring Current	<i>RTD input</i> : 0.64 mA ±0.02 mA, current flow from terminal A (under operating conditions)
Influence of Wiring Resistance	<i>Thermocouple, DC voltage input</i> : Changes in readout value at wiring resistance of 250Ω at both ends are as follows by input conversion: <ul style="list-style-type: none"> <li>• RTD: Within 300 µV</li> <li>• DC voltage: Within 750 µV</li> </ul> <i>RTD input</i> : ±0.01% FS/Ω maximum in wiring resistance range 0 to 10Ω. Range of F01 and P01: ±0.02% FS/Ω maximum.
RTD Input Allowable Wiring Resistance	<ul style="list-style-type: none"> <li>• Allowable wiring resistance is 85Ω maximum (Including Zener barrier resistance. When Zener barrier is used, this applies only to ranges other than F36 and P36. Note that site adjustment is required.)</li> <li>• Allowing wiring resistance is 10Ω maximum (This applies to ranges F01 and P01. Note that the Zener barrier cannot be used.)</li> </ul>
Allowable Parallel Resistance	<i>Thermocouple disconnection detection allowable parallel resistance</i> : 1 MΩ minimum
Maximum Allowable Input	<i>Thermocouple</i> : –0.3 to +5 Vdc <i>DC voltage input</i> : –1 to +11 Vdc
Burnout	<i>Thermocouple</i> : Upscale <i>DC voltage input</i> : Downscale

## Specifications, continued

Input 2 (DCP302 only), continued	
<b>Over-range Detection Threshold</b>	110% FS minimum: Upscale –10% FS maximum: Downscale (Note that the range of L07 is downscaled at –1% FS or less.)
<b>Cold Junction Compensation Accuracy</b>	±0.7°C (under standard conditions)
<b>Influence of Ambient Temperature on Cold Junction Compensation</b>	±0.2°C (in range 0 to 50°C)
<b>Cold Junction Compensation System</b>	Internal/external (0°C only) compensation selectable
<b>Scaling</b>	–1999 to +9999U (Settable by DC voltage range. Reverse scaling and decimal point repositioning possible.)
<b>Square Root Extraction</b>	Dropout 0.1 to 10.0%. Possible by DC voltage range.
<b>Linearization Table Approximation</b>	12 segments (both ends fixed, 11 points variable)
<b>Input Bias</b>	–1000 to +1000U variable
<b>Digital Filter</b>	0.0 to 120.0 seconds variable (filter OFF at 0.0)
<b>Relative Humidity (DCP302 only)</b>	<i>Dry Bulb (100Ω RTD): –200 to 200°C (–300 to 900°F)</i> <i>Wet Bulb (100Ω RTD): 0 to 100% RH*</i>  *From 0 to 100°C (32 to 212°F)
External Switch (RSW Input)	
<b>Number of Inputs</b>	12 maximum (4 standard and 8 optional)
<b>Types of Connectable Outputs</b>	Dry contacts (relay contact) and open-collector (current sink to ground)
<b>Terminal Voltage (open)</b>	10.4 to 12.6V (under operating conditions) across common terminal (terminal 25) and each input terminal
<b>Terminal Current (short-circuit)</b>	5.0 mA +6.6 mA across each terminal (under operating conditions)
<b>Allowable Contact Resistance (dry contact)</b>	<i>ON:</i> 700Ω maximum (under operating conditions) <i>OFF:</i> 10 kΩ minimum (under operating conditions)
<b>Residual Current (open-collector ON)</b>	3V maximum (under operating conditions)
<b>Leakage Current (open-collector OFF)</b>	0.1 mA maximum (under operating conditions)
<b>Assignments (fixed)</b>	RUN, HOLD, RESET, ADV (digital inputs 1-4)
<b>Assignments (variable)</b>	Program Number, FAST, PV start, AT, AUTO/MANUAL, G.Soak cancel, reverse/direct action (optional inputs)
<b>Input Sampling Cycle</b>	0.1 seconds
<b>ON Detection Minimum Hold Time</b>	0.2 seconds (Program No.: 0.4 seconds)

## Specifications, continued

Indication/Programmer	
<b>Upper Display</b>	Green 4-digit, 7-segment LED This normally displays PV values. Item codes are displayed in parameter setup.
<b>Lower Display</b>	Orange 4-digit, 7-segment LED This normally displays SP values and output value. Setting values are displayed in parameter setup.
<b>Program Number Display</b>	Green 2-digit, 7-segment LED This normally displays program number.
<b>Segment Number Display</b>	Green 2-digit, 7-segment LED This normally displays segment number. Item numbers are displayed in parameter setup, and alarm number is displayed when alarm occurs.
<b>Profile Display</b>	6 orange LEDs Displays program pattern rise, soak and fall tendencies.
<b>Status Displays</b>	24 round LEDs <i>Modes:</i> RUN, HLD, MAN, PRG (green) <i>Display details:</i> PV, SP, OUT, TM, CYC, CH1, CH2 (green) <i>Battery voltage:</i> BAT (red) (blinks at low voltage) <i>Status:</i> AT, OT1, OT2, OT3 (orange) <i>Events:</i> EV1, EV2, EV3, T1, T2, T3, T4, T5 (orange)
<b>Operation Keys</b>	13 rubber keys
Mode	
<b>Program Operation Mode</b>	READY: Ready to run program (control stop/program number selectable) RUN: Program run HOLD: Program hold FAST: Program fast-forward END: Program end
	AUTO: Automatic operation MANUAL: Manual operation (output controlled on console)
<b>Constant-Value Operation Mode</b>	READY: Ready to run program (control stop) RUN: Program running
	AUTO: Automatic operation MANUAL: Manual operation (output controlled on console)

## Specifications, continued

Control	
<b>PID Control</b>	<p><b>Proportional band (P)</b> 0.1 to 999.9%</p> <p><b>Rate time (I)</b> 0 to 3600 seconds. PD control if set to 0.</p> <p><b>Reset time (D)</b> 0 to 1200 seconds. PI control if set to 0.</p> <p><b>MV limit</b> <i>Lower limit:</i> -10.0 to upper limit % <i>Upper limit:</i> Lower limit to +110.0%</p> <p><b>Manual reset</b> 0.0 to 100.0%</p> <p><b>Number of PID sets</b> 8 sets for program operation plus 1 set for constant-value operation</p> <p><b>PID set selection</b> Segment designation/automatic zone selection can be switched by program operation</p> <p><b>MV change limit</b> 0.1 to 10.0%/0.01 seconds, no limit by 0.0</p> <p><b>Autotuning</b> Automatic setting of PID value by limit cycle system plus Neuro and Fuzzy (2 degrees of freedom PID) and Smart systems (not possible on heat/cool channel)</p> <p><b>Position-proportional dead zone</b> 0.5 to 25.0% (settable on 2G output model)</p> <p><b>Heat/cool dead zone</b> -100.0 to +50.0% (settable on 3D and 5K output models)</p>
<b>Three Position Control</b>	<p><b>Deviation lower/upper limit, Deviation lower/upper limit hysteresis</b> 0 to 1000U (settable when 3-position control is selected on 3D output models)</p>
<b>Reverse/Direct Action Switching</b>	Switchable (output other than heat/cool)
<b>Programmer Function</b>	<p><i>Switching:</i> mV output can be switched to SP output (current output)</p> <p><i>Scaling:</i> Supported</p> <p><i>Output resolution:</i> 1/10000</p>
<b>Auxiliary Output</b>	<p><i>Type:</i> PV, SP, deviation, MV, MFB</p> <p><i>Scaling:</i> Supported</p> <p><i>Output resolution:</i> 1/10000</p>
Output	
<b>0D Output 1</b> <b>3D Outputs 1, 2, 3</b>	<p><b>Relay contact output</b></p> <p><i>Contact type:</i> 1a1b</p> <p><i>Contact rating:</i> 5A (30 Vdc, resistive load) 5A (120 Vac, resistive load) 4A (240 Vac, resistive load)</p> <p><i>Allowable contact voltage:</i> 250 Vac, resistive load 125 Vdc, resistive load</p> <p><i>Maximum switching power:</i> 150W, resistive load 960 VA, resistive load</p> <p><i>Life:</i> 100,000 operations (resistive load at contact rating, frequency: 30 operations/minute)</p> <p><i>Minimum switching voltage:</i> 5V</p> <p><i>Minimum switching current:</i> 100 mA</p> <p><i>Output resolution:</i> 1/1000</p> <p><i>Time-proportional cycle:</i> 5 to 120 seconds</p>

**Specifications, continued**

<b>Output, continued</b>	
<p><b>2G Output 1</b></p>	<p><b>M/M drive relay</b>  <i>Contact type:</i> 1a (2 circuits)  <i>Contact rating:</i> 2.5A (30 Vdc, L/R = 0.7 ms)            4A (120 Vac, cos<math>\phi</math> = 0.4)            2A (240 Vac, cos<math>\phi</math> = 0.4)  <i>Allowable contact voltage:</i> 250 Vac, cos<math>\phi</math> = 0.4            125 Vdc, L/R = 0.7 ms  <i>Maximum switching power:</i> 75W (L/R = 0.7 ms)            480 VA (cos<math>\phi</math> = 0.4)  <i>Life:</i> 100,000 operations            (cos<math>\phi</math> = 0.4 at contact rating,            frequency: 30 operations/minute)  <i>Minimum switching voltage:</i> 5V  <i>Minimum switching current:</i> 100 mA  <i>MFB (motor feedback) input range:</i> 100 to 2500<math>\Omega</math>  <i>Control at MFB disconnection:</i> ON/OFF for continuation of operation according to MFB            estimated position can be selected</p>
<p><b>5G Outputs 1, 2</b>  <b>5K Outputs 1, 2, 3</b>  <b>Auxiliary Outputs 1, 2</b></p>	<p><b>Current output</b>  <i>Output current:</i> 4 to 20 mA dc / 0 to 20 mA dc  <i>Allowable load resistance:</i> 600<math>\Omega</math> maximum (under operating conditions)  <i>Output accuracy:</i> <math>\pm</math>0.1% FS maximum (under standard conditions)            Note that output accuracy becomes <math>\pm</math>0.5% FS when 0 to 20 mA output is 5% or less.  <i>Output resolution:</i> 1/10000  <i>Inrush current:</i> 25 mA maximum for 50 ms maximum (at 250<math>\Omega</math> load)  <i>Maximum output current:</i> 22.0 mA dc  <i>Minimum output current:</i> 0.0 mA dc  <i>Output updating cycle:</i> 0.1 seconds  <i>Open terminal voltage:</i> 25V maximum (output 1)            18V maximum (output 2, output 3, auxiliary output)</p>
<p><b>5G Outputs 1, 2</b>  <b>5K Outputs 1, 2, 3</b>  <b>(when current output is switched to voltage output)</b></p>	<p><b>Voltage output</b>  <i>Allowable load resistance:</i> 600<math>\Omega</math> maximum (under operating conditions)  <i>Inrush current:</i> 25 mA maximum for 50 ms maximum (at 250<math>\Omega</math> load)  <i>Load current adjustment:</i> 2 to 22 mA variable  <i>Open terminal voltage:</i> 25V maximum (output 1)            18V maximum (output 2, output 3)  <i>OFF leakage current:</i> 100 <math>\mu</math>A maximum  <i>Output response time:</i> At ON-OFF 600<math>\Omega</math> load: 0.5 ms maximum            At OFF-ON 600<math>\Omega</math> load: 1.0 ms maximum  <i>Output resolution:</i> 1/1000  <i>Time-proportional cycle:</i> 1 to 60 seconds variable</p>
<b>Event/Time Event Output</b>	
<p><b>Events 1, 2</b></p>	<p><b>Relay contact output</b>  <i>Contact type:</i> 1a  <i>Contact rating:</i> 1A (240 Vac/30 Vdc, resistive load)  <i>Life:</i> 100,000 operations (at rating)  <i>Minimum switching voltage, current:</i> 10V, 10 mA</p>
<p><b>Event 3</b></p>	<p><b>Relay contact output</b>  <i>Contact type:</i> 1a1b  <i>Contact rating:</i> 2A (240 Vac/30 Vdc, resistive load)  <i>Life:</i> 100,000 operations (at rating)  <i>Minimum switching voltage, current:</i> 10V, 10 mA</p>
<p><b>Time Events 1 to 5</b></p>	<p><b>Open-collector output</b>  <i>External supply voltage:</i> 10 to 29 Vdc  <i>Maximum load current:</i> 70 mA/load  <i>OFF leakage current:</i> 0.1 mA maximum  <i>ON residual voltage:</i> 1.6V maximum</p>

## Specifications, continued

Event/Time Event Output, continued	
<b>Event 1 to 3 Settings</b>	<p><b>Event type</b>  <i>PV type events:</i> PV, deviation, absolute value deviation, SP, MV, MFB  <i>Controller status events:</i> RUN+HOLD+FAST+END, READY, RUN, HOLD, FAST, END, G.Soak standby, MANUAL, autotuning executing, constant-value operation, MFB estimated position control, sum of all alarms, PV range alarm, controller alarms, low battery voltage, setting on console, ADV</p> <p><i>Time events</i>  <b>Event standby</b>            ON/OFF selectable  <b>Event hysteresis</b>            0 to 200U (event types PV, deviation, absolute value deviation or SP)            0.0 to 20.0% (event types MV or MFB)  <b>Event ON delay</b>            0 to 3600 seconds</p>
<b>Time Event 1 to 5 Settings</b>	<p><i>Time event type:</i>            Time events, segment number events</p>
Communications	
<b>Communications System</b>	<p><i>Communications standard:</i> RS485 ASCII  <i>Network:</i> Multi-drop (DCP300 provided with only slave node functionality)            1 to 31 units maximum  <i>Data flow:</i> Half duplex  <i>Synchronization:</i> Start-stop synchronization</p>
<b>Interface System</b>	<p><i>Transmission system:</i> Balanced (differential)  <i>Data line:</i> Bit serial  <i>Signal line:</i> 5 transmit/receive lines (3-wire connection also possible)  <i>Transmission speed:</i> 4800, 9600 bps  <i>Transmission distance:</i> 500m maximum (total)  <i>Other:</i> Conforming to RS-485 ASCII</p>
<b>Display Characters</b>	<p><i>Character bit count:</i> 11 bits/character  <i>Format:</i> 1 start bit, event parity, 1 stop bit; or            1 start bit, no parity, and 2 stop bits  <i>Data length:</i> 8 bits</p>
<b>Isolation</b>	All inputs and outputs are completely isolated.
RS485 communications can be performed by connecting to a computer equipped with an RS485 interface or using an RS232C to RS485 converter.	
General Specifications	
<b>Memory Backup</b>	<p><i>Memory:</i> Battery backed-up RAM  <i>Battery life:</i> Controller power OFF—Approximately 3 years under standard conditions            Controller power ON—Approximately 10 years under standard conditions</p>
<b>Rated Power Voltage</b>	90 to 264 Vac, 50/60 Hz
<b>Power Consumption</b>	30 VA maximum
<b>Power ON Rush Current</b>	15A maximum, 10 ms (under operating conditions)
	<p><b>Handling Precautions</b>            When starting up a number of DCP300s simultaneously, ensure ample power is supplied or stagger startup times. Otherwise, the controllers may not start normally due to inrush current induced-voltage drop. Voltage must stabilize within two seconds after power ON.</p>
<b>Power ON Operation</b>	<i>Reset time:</i> 15 seconds maximum (time until normal operation possible under normal operating conditions)

## Specifications, continued

General Specifications, continued	
<b>Allowable Transient Power Loss</b>	20 ms maximum (under operating conditions)
<b>Insulation Resistance</b>	Minimum 20 MΩ across power terminals 1 or 2 and ground terminal 3 (using a 500 Vdc megger)
<b>Dielectric Strength</b>	1500 Vac 50/60 Hz for 1 minute across power terminal and ground terminal 1500 Vac 50/60 Hz for 1 minute across relay output and ground terminal 500 Vac 50/60 Hz for 1 minute across non-power terminal and ground terminal 500 Vac 50/60 Hz for 1 minute across isolated terminals
<b>Standard Conditions</b>	<i>Ambient temperature:</i> 23 ±2°C <i>Ambient humidity:</i> 60 ±5% RH <i>Rated power voltage:</i> 105 Vac ±1% <i>Power frequency:</i> 50 ±1 Hz or 60 ±1 Hz <i>Vibration resistance:</i> 0 m/s <sup>2</sup> <i>Impact resistance:</i> 0 m/s <sup>2</sup> <i>Mounting angle:</i> Reference plane (vertical) ±3°
<b>Operating Conditions</b>	<i>Ambient temperature range:</i> 0 to 50°C (temperature at case bottom when closely mounted) <i>Ambient humidity range:</i> 10 to 90% RH (no condensation) <i>Rated power voltage:</i> 90 to 264 Vac <i>Power frequency:</i> 50 ±2 Hz or 60 ±2 Hz <i>Vibration resistance:</i> 0 to 1.96 m/s <sup>2</sup> <i>Impact resistance:</i> 0 to 9.80 m/s <sup>2</sup> <i>Mounting angle:</i> Reference plane (vertical) ±10°
<b>Installation Types</b>	Permanent connection type unit, indoor mounting, panel mounting
<b>Applicable Standards</b>	EN61010-1, EN50081-2, EN50082-2 (CE Marking declaration)
<b>Installation Category</b>	Category II (IEC664-1, EN61010-1)
<b>Pollution Degree</b>	2
<b>Fuse</b>	<i>Rating:</i> IEC127 <i>Cutoff speed:</i> Delayed operation type (T) <i>Rated voltage:</i> 250V <i>Rated current:</i> 1A
<b>Transport/Storage Conditions</b>	<i>Ambient temperature:</i> -20 to +70°C <i>Ambient humidity:</i> 10 to +95% RH (no condensation) <i>Vibration resistance:</i> 0 to 4.90 m/s <sup>2</sup> (10 to 60 Hz for 2 hours each in X, Y and Z directions) <i>Impact resistance:</i> 0 to 490 m/s <sup>2</sup> (3 times vertically) <i>Package drop test:</i> Drop height: 60 cm (1 corner, 3 edges and 6 planes; free fall)
<b>Terminal Screw</b>	M3.5 self-tapping screw
<b>Terminal Screws Tightening Torque</b>	0.78 to 0.98 N·m (6.9 to 8.6 inch-pounds)
<b>Mask/Case Materials</b>	<i>Mask:</i> Multilon <i>Case:</i> Polycarbonate
<b>Mask/Case Color</b>	<i>Mask:</i> Dark gray (Munsell 5Y3.5/1) <i>Case:</i> Light gray (Munsell 2.5Y7.5/1)
<b>Installation</b>	Specially designed mounting bracket
<b>Weight</b>	Approximately 900 g

TABLE 1 – Input 1 Types and Ranges (selectable in setup)

Type	Input Type	Range No.	Code	Temperature Range	
				°C	°F
Thermocouple	K (CA)	0	K09	0 to 1200	0 to 2400
	K (CA)	1	K08	0.0 to 800.0	0 to 1600
	K (CA)	2	K04	0.0 to 400.0	0 to 750
	K (CA)	3	K29	-200 to +1200	-300 to +1200
	K(CA)	4	K44	-200.0 to +300.0	-300 to +700
	K (CA)	5	K46	-200.0 to +200.0	-300 to +400
	E (CRC)	6	E08	0.0 to 800.0	0 to 1800
	J (IC)	7	J08	0.0 to 800.0	0 to 1600
	T (CC)	8	T44	-200.0 to +300.0	-300 to +700
	B (PR30-6)	9	B18	0 to 1800	0 to 3300
	R (PR13)	10	R16	0 to 1600	0 to 3100
	S (PR10)	11	S16	0 to 1600	0 to 3100
	W (WRe5-26)	12	W23	0 to 2300	0 to 4200
	W (WRe5-26)	13	W14	0 to 1400	0 to 2552
	PR40-20	14	D19	0 to 1900	0 to 3400
	Ni-Ni-Mo	15	Z13	0 to 1300	32 to 2372
	N	16	U13	0 to 1300	32 to 2372
	PL II	17	Y13	0 to 1300	32 to 2372
	DIN U	18	Z08	-200.0 to +400.0	-300 to +750
	DIN L	19	Z07	-200.0 to +800.0	-300 to +1600
Golden-iron-chromel	20	Z06	0.0 to 300.0K	—	
Resistance Temperature Detector (RTD)	JIS'89 Pt100 (IEC Pt100 Ω)	32	F50	-200.0 to +500.0	-300 to +900
		33	F46	-200.0 to +200.0	-300 to +400
		34	F32	-100.0 to +150.0	-150.0 to +300.0
		35	F36	-50.0 to +200.0	-50.0 to +400.0
		36	F38	-60.0 to +40.0	-76.0 to +104.0
		37	F33	-40.0 to +60.0	-40.0 to +140.0
		38	F05	0.0 to 500.0	0.0 to 900.0
		39	F03	0.0 to 300.0	0.0 to 500.0
	JIS'89 JPt100	40	F01	0.00 to 100.00	0.0 to 200.0
		48	P50	-200.0 to +500.0	-300 to +900
		49	P46	-200.0 to +200.0	-300 to +400
		50	P32	-100.0 to +150.0	-150.0 to +300.0
		51	P36	-50.0 to +200.0	-50.0 to +400.0
		52	P38	-60.0 to +40.0	-76.0 to +104.0
		53	P33	-40.0 to +60.0	-40.0 to +140.0
		54	P05	0.0 to 500.0	0.0 to 900.0
55	P03	0.0 to 300.0	0.0 to 500.0		
56	P01	0.00 to 100.00	0.0 to 200.0		

Type	Input Type	Range No.	Code	Range (Programmable)
DC Current	4 to 20 mA	64	C01	-1999 to +9999
	0 to 20 mA	65	C08	
DC Voltage	0 to 10 mV	66	M01	
	-10 to +10 mV	67	L02	
	0 to 100 mV	68	L01	
	0 to 1V	69	L04	
	-1 to +1V	70	L08	
	1 to 5V	71	V01	
	0 to 5V	72	L05	
0 to 10V	73	L07		

TABLE 2 – Input 2 (DCP302 only) Types and Ranges (selectable in setup)

Type	Input Type	Range No.	Code	Temperature Range	
				°C	°F
Thermocouple	K (CA)	128	K44	-200.0 to +300.0	-300 to +700
	K (CA)	129	K29	-200 to +1200	-300 to +2400
Resistance Temperature Detector (RTD)	JIS'89 PT100 (IEC Pt100Ω)	160	F36	-50.0 to +200.0	-50.0 to +400.0
		161	F01	0.00 to 100.00	0.0 to 200.0
	JIS'89 JPt100	176	P36	-50.0 to +200.0	-50.0 to +400.0
		177	P01	0.00 to 100.00	0.0 to 200.0
Type	Input Type	Range No.	Code	Range (Programmable)	
DC Voltage	0 to 10V	192	L07	-1999 to +9999	
	1 to 5V	193	V01		

NOTES FOR TABLE 1 AND TABLE 2:

- Readout Accuracy (items outside of ±0.1% FS range)
  - At -100°C maximum of K and T thermocouples: ±1°C ±1U
  - At 260°C maximum of B thermocouple: ±4% FS ±1U  
At 260 to 800°C: ±0.4% FS ±1U  
At 800 to 1800°C: ±0.2% FS ±1U
  - At 100°C maximum of R and S thermocouples: ±0.2% FS ±1U  
At 100 to 1600°C: ±0.15% FS ±1U
  - At 300°C maximum of PR40-20 thermocouple: ±2.5% FS ±1U  
At 300 to 800°C: ±1.5% FS ±1U  
At 800 to 1900°C: ±0.5% FS ±1U
  - Golden iron chromel thermocouple: ±1.5%K ±1U
  - 2-digit range past decimal point by RTD input: ±0.15% FS ±1U
  - At 0 to 10 mV range: ±0.15% FS ±1U
  - At -100°C maximum of DIN U thermocouple: ±2°C ±1U  
At -100 to 0°C: ±1°C ±1U
  - At -100°C maximum of DIN L thermocouple: ±1.5°C ±1U
- The unit of code Z06 is Kelvin (K).
  - The lower limit readout of code B18 is 20°C (68°F).
  - The lower limit readout (°C) of codes K44, K46, T44, Z08, and Z07 is -199.9°C.
  - The lower limit readout (°C) of codes F50, F46, P50, and P46 is -199.9°C.
  - The upper limit readout (°C) of codes F01 and P01 is 99.99°C.
  - The PV lower limit alarm does not occur with code F50.
- The number of digits past the decimal point for DC current and DC voltage is programmable within the range 0 to 3.
- The readout accuracy of M01 is ±0.15% FS ±1U

## Dimensions

Dimensions: millimeters/inches

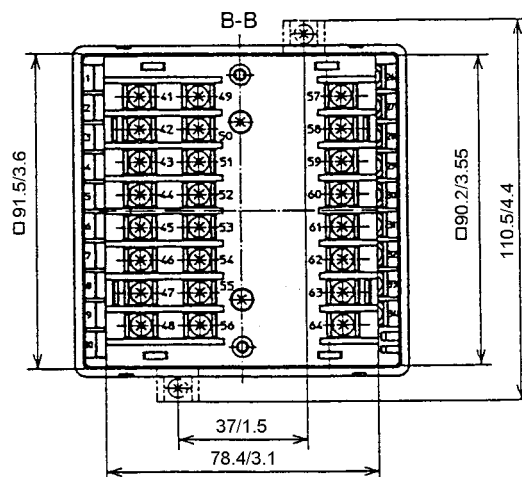
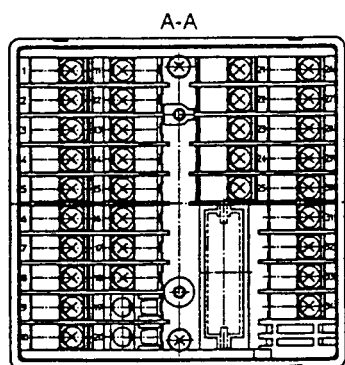
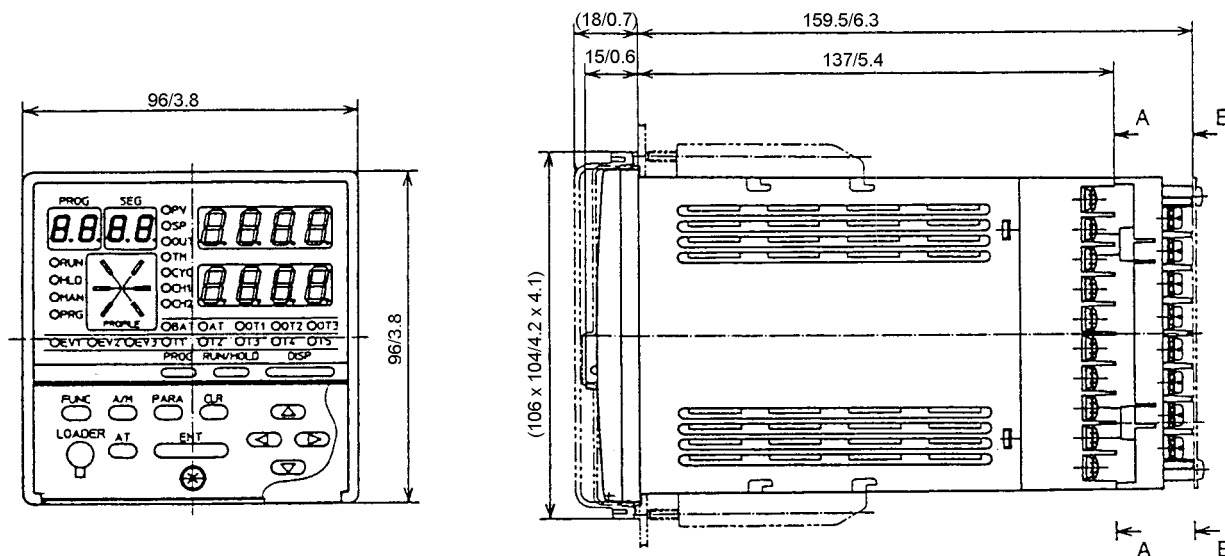

### PANEL CUTOUT

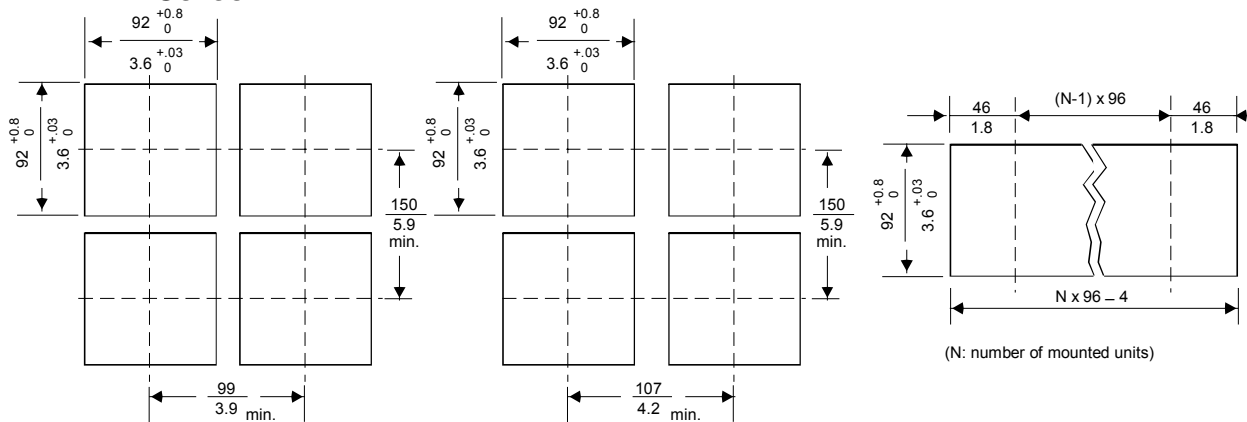

Using the soft dust-proof cover set

Using the hard dust-proof cover set

Close horizontal mounting

## Wiring

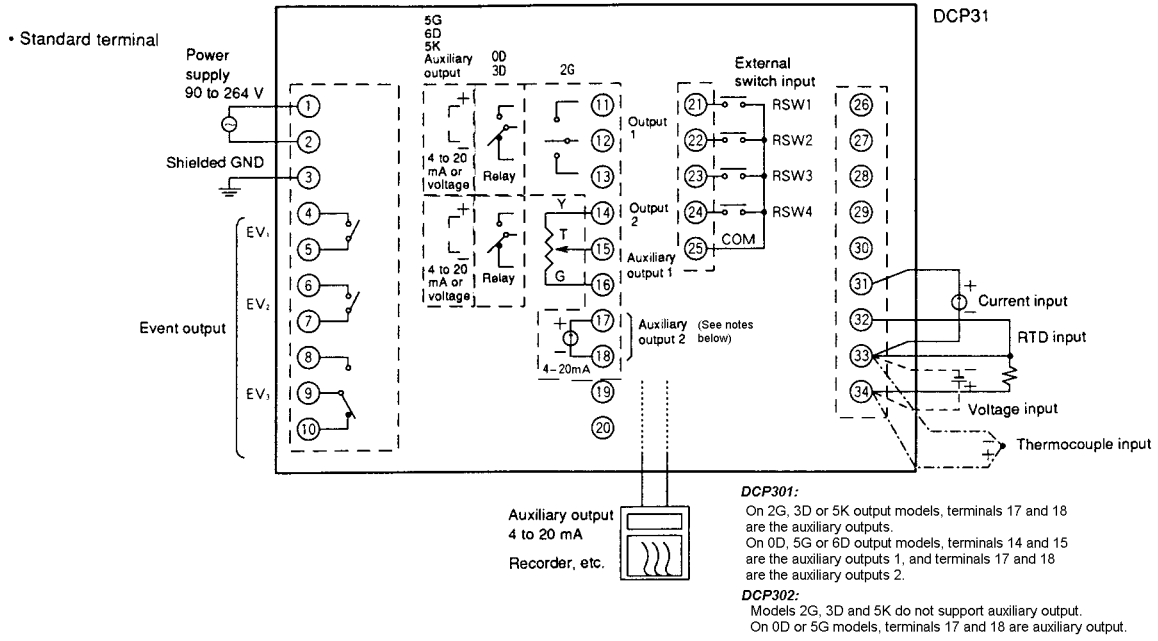

• Add-on terminal

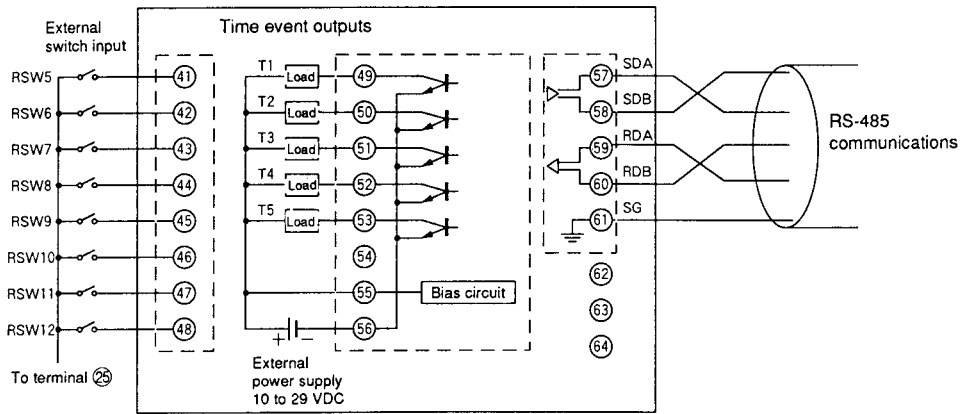

## Model Selection Guide

### Instructions

- Select the desired Key Number. The arrow to the right marks the selection available.
- Make one selection each from Table I thru VI, using the column below the proper arrow.
- A dot (•) denotes unrestricted availability. A letter denotes restricted availability.

**Key Number**    I    II    III    IV    V    VI  
 [ ] - [ ] - [ ] - [ ] - [ ] - [ ]

KEY NUMBER	Description	Selection	Availability	
1	1 Channel Digital Controller/Programmer	P301	↓	
2	2 Channel Digital Controller/Programmer	P302		↓

**TABLE I**

Outputs	Channel 1	Channel 2 (P302 Only)			
	Relay (5 Amp)	Current			
	Position Proportional	Current	2G	•	•
	Current (4 - 20 mA)	Current	5G	•	•
	Relay/Relay (Heat/Cool)	Current	3D	•	•
	Current/Current (Heat/Cool)	Current	5K	•	•

**TABLE II**

Inputs				
	One Input Channel	0	•	
	Two Input Channels	1		•
	Temperature/Relative Humidity Calculation	2		•

**TABLE III**

Power				
	Universal Power - 90 to 264 VAC, 50/60 Hz	ES	•	•

**TABLE IV**

Option 1				
	None	00	•	•
	1 Auxiliary Output (Only OD, 5G for P301)	01	•	a
	2 Auxiliary Outputs (Only 1 available on Output 2G, 3D, 5K)	02	a	

**TABLE V**

Option 2				
	4 Digital Inputs + 3 Events - (Standard features)	0	•	•
	12 Digital Inputs + 3 Events + 5 Time Events	1	•	•
	12 Digital Inputs + 3 Events + 5 Time Events + RS485 ASCII Communications	2	•	•

**TABLE VI**

Additional Processing				
	None	00	•	•

### RESTRICTIONS/NOTES

Restriction Letter	Not Available With		Available Only With	
	Table	Selection	Table	Selection
a	I	2G, 3D, 5K	I	0D, 5G

Refer to Model Selection Guide.

## Ordering Information

For more information, contact Honeywell at the number listed below.

*Specifications are subject to change without notice.*

Distributor :



Tlf: 67150 250 Faks: 67 150 251

Mail: [post@instrumentteam.no](mailto:post@instrumentteam.no)

Web: [www.instrumentteam.no](http://www.instrumentteam.no)

# Honeywell

## Industrial Measurement and Control

<http://europe.iac.honeywell.com>

Northern Europe and Southern Africa : Honeywell Ltd., Arlington Business Park, Bracknell, RG21 1EB, UK – Tel :[44] 1344 656000

Central Europe : Honeywell A.G., Kaiserleistr e 39, 63067 Offenbach, Germany – Tel:[49] 69-8064-0

Western and Southern Europe : Honeywell S.A., Avenue de Schiphol 3, 1140 Brussels, Belgium – Tel: [32-2] 728 2611

Eastern Europe : Honeywell s.r.o., Budejivicka 1, 140 21 Prague 4, Czech Republic – Tel:[420-2] 6112-2777

Middle East: Honeywell Middle East Ltd., Khalifa Street, Sheikh Faisal Building, Abu Dhabi, U.A.E. – Tel:[9712] 322530

Asia: Honeywell Asia Pacific Inc., Room 3213-3225, Sun Hung Kai Centre, 30 Harbour Rd., Wanchai, Hong Kong - Tel: [852] 23319133

Japan: Industrial Operations Tokyo, 4-28-1 Nishi-Rokugo Othu-ku, Tokyo 144, Japan - Tel: [81] 3-3486-2051