

Type series F

Pressure transmitters, mechanical-inductive

Operating method

Pressure transmitters are used to convert over-pressure, vacuum or differential pressure into a proportional electrical signal of 0–10 V, 0–20 mA (4–20 mA). A metal bellows or diaphragm is exposed to the occurring pressure. The pressure-dependent movements of the metal bellows

are transmitted free of play to an inductive displacement sensor. The electronic system converts the position of the displacement sensor into a proportional electrical signal (voltage and injected current).

General technical information

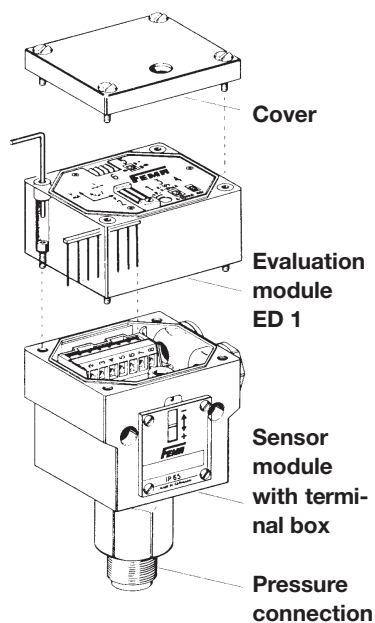

Operating principle

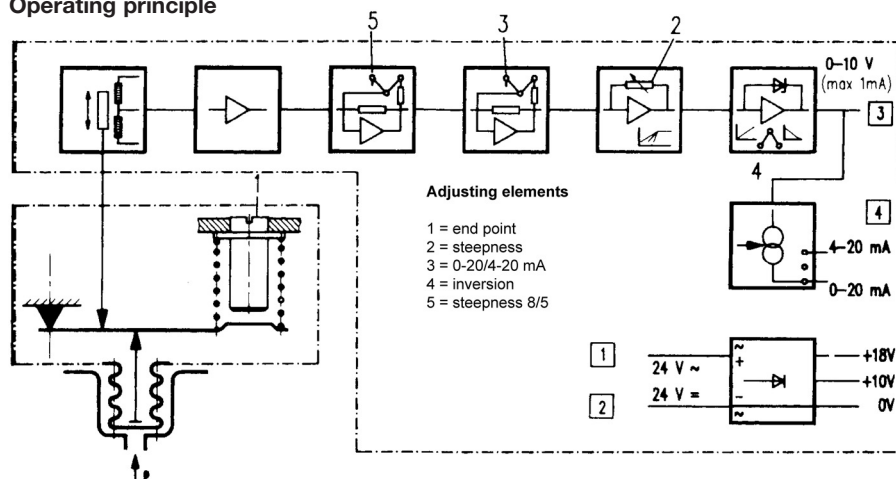

A complete transmitter consists of a sensor module with pressure and electrical connections, an evaluation module and a cover.

Additional evaluation modules can be plugged in.

Type series	F...+ ED 1	F...+ ED 3
Electrical connection	<p>Terminal connection</p> <p>Output signal 0–10 V and 0–20 mA</p>	<p>Plug connection</p> <p>Output signal 0–10 V</p>
Voltage output characteristic		
Current output characteristic		



Pressure FN... + ED 1

Differential pressure FHBN... + ED 1

Type series F... + ED 1

with terminal connection

Pressure transmitter with 3 conductors

- with 2 output signals 0–10 V and 0–20 mA
- Switchable to 2–10 V and 4–20 mA and invertible
- Plug-in display module AZ 331

Pressure transmitters of the F series produce 0–10 V / 0–20 mA. Both signals are applied to the terminal strip and can be used in parallel. A

complete transmitter consists of a sensor parts and the plug-in evaluation module ED 1.

Removing the cover gives access to an operator interface for adjusting the operating range.

A plug-in digital display AZ 331 is available to display the output signal in any units (voltage / current / pressure / differential pressure). For further details see Datasheet AZ.

Characteristic of a transmitter (nominal range)

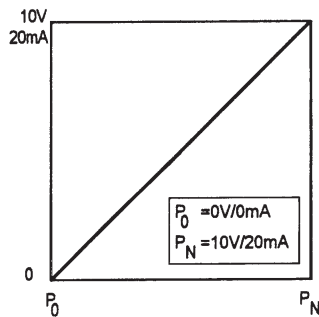

Product Summary

Operating range (nominal range) P_0 – P_N	Smallest adjustable operating range	Max. permissible pressure (approx. values)	Sensor material	Type
--	-------------------------------------	--	-----------------	------

Overpressure

0 – 50 mbar	20 mbar	2.5 bar		FN 505 + ED 1
0 – 100 mbar	25 mbar	5 bar		FN 510 + ED 1
0 – 250 mbar	65 mbar	6 bar	1.4104	FN 025 + ED 1
0 – 500 mbar	125 mbar	6 bar	+	FN 05 + ED 1
0 – 1 bar	250 mbar	6 bar	1.4571	FN 1 + ED 1
0 – 2.5 bar	0.7 bar	16 bar		FN 3 + ED 1

Vacuum

–1 to 0 bar	250 mbar	6 bar	1.4104	FVN 111 + ED 1
–1 to 1 bar	500 mbar	6 bar	+	FVN 112 + ED 1
–1 to 5 bar	1.5 mbar	25 bar	1.4571	FVN 105 + ED 1
–250 to +250 mbar	125 mbar	3 bar		FVN 125 + ED 1

Differential pressure

0 – 500 mbar	125 mbar	10 bar		FHBN 05 + ED 1
0 – 1 bar	250 mbar	15 bar	1.4305	FHBN 1 + ED 1
0 – 2.5 bar	0.7 bar	15 bar	+	FHBN 3 + ED 1
0 – 5 bar	1.25 mbar	15 bar	1.4571	FHBN 5 + ED 1
0 – 10 bar	2.5 mbar	25 bar		FHBN 10 + ED 1

+ Accessories

- Plug-in display module AZ 331
- Programmable display APV 630

For differential pressure

- Valve combination VKD 3, VKD 5
- Threaded joint with male adapter union MAU 8

i Note

- If measured values diverge due to higher static (system) pressure, observe the adjustment instructions on page 71.

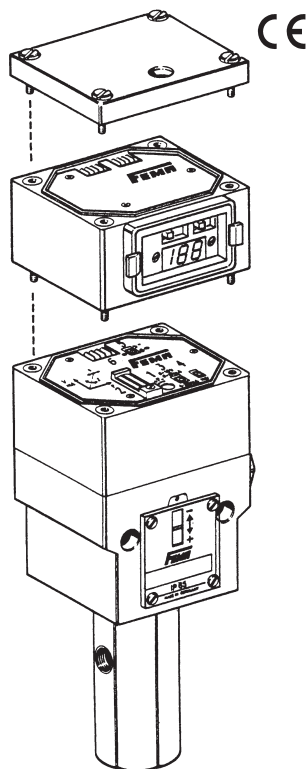

All plugged-in modules are powered via the terminal strip of the sensor module (on ED 1) or via the plug connection. The output signal is sent from each module for further evaluation via the same route. The power consumption increases by approx. 1 W for each additional module plugged in.

Connection schemes

Terminal connection

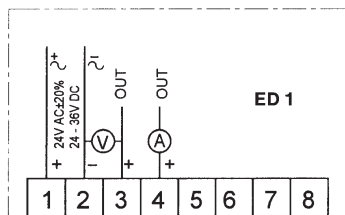

Plug connection

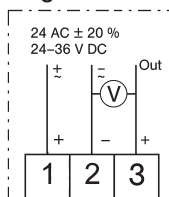

ED 3 output signal 0–10 V

Type series F

Technical data

Supply voltage

24 V AC \pm 20% or 24–36 V DC

Power consumption

Signal and supply voltage is connected to the sensor module.
max. 1 W

Outputs (short-circuit proof)

0–10 V, 2–10 V (\pm 1 mA),
0–20 mA, 4–20 mA (3-conductor system)
All outputs are invertible.

Load impedance

max. 750 Ohm.

Direction of action

Rising pressure produces a rising output signal (default setting).
Invert with slide switch 4.

Output signal

0–10 V and 0–20 mA

Voltage and current output can also be picked up and used simultaneously. Terminals 5–8 are reserved for later expansions and must not be connected as this would destroy the device.

Operating mode

mechanical, inductive

Sensor element

Pressure bellows or diaphragm

Pressure connection

G 1/2 external and G 1/4 internal.

On FH types: G 1/4 internal.

Cable entry

2 x M 16 x 1.5

Degree of protection

IP 65

Installation

Directly on the pressure line or mounted on wall with two 4 mm \varnothing screws.

Materials

see Product Summary.

Linearity

The maximum linearity error is approx. 1% of full scale.

Hysteresis

approx. 0.5% nominal range, related to full output
0–10 V or 0–20 mA.

Long-term drift

0.2% FS / year

Repetition accuracy

approx. 0.2%

Accuracy class

1.0

Temperature drift

Range from 20–45°C approx. 0.02%/K

Range from 0–20°C approx. 0.05%/K

< = 3%/bar (see adjusting instructions, page 72)

Influence of static pressure

Mounting position

Vertical. With other mounting positions, the degree of protection and accuracy are different.

Ambient temperature

0 to 45°C

Max. medium temperature

70°C. Temperatures may reach 85°C for short periods. Higher medium temperatures are possible if the above limit values for the switching device are ensured by suitable measures (e.g. siphon).

Storage temperature

–20 to +70°C

! Important:

When connecting to control systems with a common AC supply, the ground conductor must be looped through. That is to say, on all devices in the system, the same reference potential must be present at the corresponding ground terminal (terminal 2). In the case of a DC supply, ensure correct polarity.

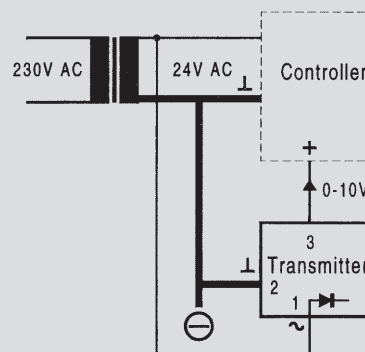

Type series F

Adjustment and operation

Operating ranges and output signals are adjustable over a wide range.

An outstanding characteristic of the pressure transmitters is the variability of the characteristic curve, which means that the pressure range and output signal can be adapted to any subsequent control system.

- P_0 = starting pressure of nominal range
- P_N = nominal pressure (end point of nominal range)
- P_A = starting pressure of set range
- P_E = end pressure of set range

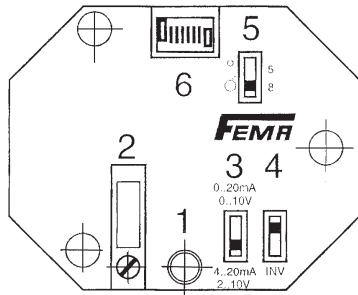

Operator interface ED 1

- 1 = Setting spindle for setting the final value P_E
- 2 = Setting potentiometer for setting the initial value P_A
- 3 = Slide switch for selecting the output signal 0–20 mA (0–10 V) or 4–20 mA (2–10 V)
- 4 = Slide switch for inverting the output signal
- 5 = Slide switch for changing the steepness of the characteristic in a ratio of 8:5.
Normal position: 8
For smaller operating ranges (< approx. 70% of the nominal range), select position 5
- 6 = Plug connector for further evaluation modules

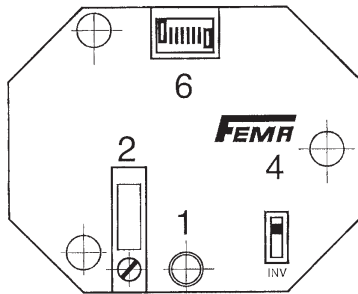

Operator interface ED 3

- 1 = Setting spindle for setting the final value P_E
- 2 = Setting potentiometer for setting the initial value P_A
- 4 = Slide switch for inverting the output signal
- 6 = Plug connector for further evaluation modules

Output signals for module ED 1

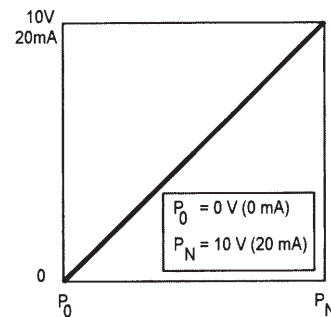

Basic setting

The factory default setting covers the nominal range P_0 (usually 0 bar) to P_N .

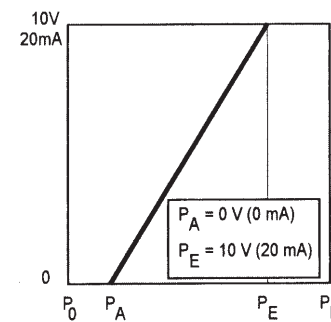

Altering the range

The range can easily be altered by shifting the end point and adjusting the steepness of the characteristic curve.

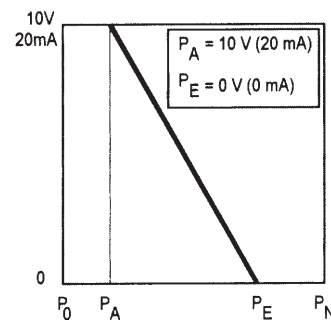

Inversion

The output signal can be inverted by means of a slideswitch.

Output signals for module ED 3

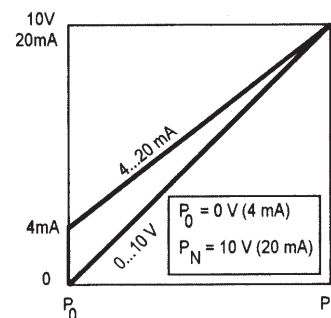

Range alteration and inversion as above.

The current signal can be reduced below 4 mA (down to approx. 2.5 mA). If the installation has a fault alarm system, the response threshold should be set below 2.5 mA.



Type series F

Setting and testing

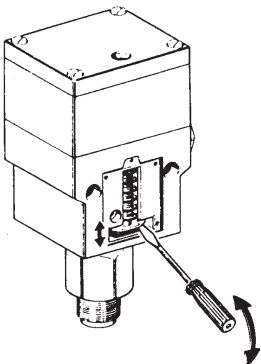
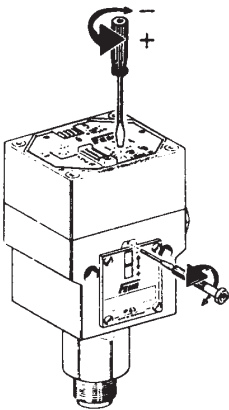
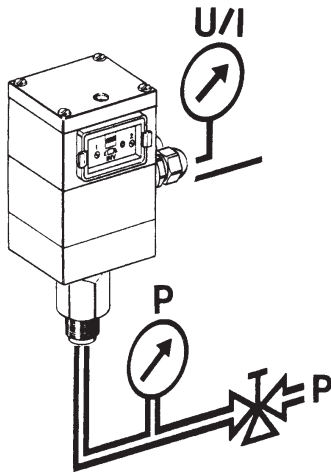

Altering the operating range

To check functioning or change the settings from outside the system, a test set-up is required which meets the following requirements:

1. It must be possible to apply pressure to the pressure transmitter up to the desired final value. The pressure must be displayed by a sufficiently accurate pressure gauge.
2. To display the output signal a voltmeter with a measuring range of 0–10 V (preferably 0–15 V) or an ammeter with a measuring range of 0–20 mA (preferably 0–25 or 0–30 mA) are required.
3. To supply power to the transmitter, a 24 V AC or 24 V DC voltage source is needed.

Setting operations must be carried out in the correct sequence

1. Remove the plastic cover
2. Set the slide switches (3) and (4) to the correct position (switch 3 is only present on ED 1)
Switch (3): Output signal 0–10 V / 0–20 mA or 4–20 mA / 2–10 V (only on ED 1)
Switch (4): Direction of action
Switch up rising pressure = rising output signal
Switch down (INV): rising pressure = falling output signal
3. Loosen the locking screw above the cover glass (approx. 2 turns anticlockwise)
4. Apply final pressure P_{ϵ}
5. Using a screwdriver, turn the setting spindle (1) to the desired output signal (depending on position of slide switches (3) and (4): 10 V, 20 mA, 0 V, 0 mA, 4 mA)
6. Apply starting pressure P_{Δ}
With the potentiometer (2), adjust the output signal to the desired value (depending on position of slide switches: 0 V, 0 mA, 10 V, 20 mA, 4 mA)
7. Check the setting again and then retighten the locking screw for the setting spindle.

Important: Always set the upper final value P_{ϵ} with the setting spindle (1) first, and then the lower initial value P_{Δ} with the potentiometer (2).

Generating an output signal without pressure

It can often be very useful to generate an output signal before commissioning the system, in order to check electrical operation, the direction of action and the functioning of downstream control elements. The procedure is as follows:

1. Loosen the four screws on the scale window and remove the cover glass, scale plate and rubber seal.
2. In the lower, wide part of the cut-out in the housing, insert the tip of a small screwdriver underneath the bridge.
3. Carefully move the bridge up and down. When the supply voltage is applied, the output signal should change depending on the movements of the bridge.
4. Check the direction of action. Upward movement of bridge corresponds to rising pressure.
5. Once you have finished testing, carefully screw the parts back on again in the following order: rubber seal, scale plate, cover glass.

Caution: In the event of incorrect assembly, IP 65 protection is no longer assured.

Adjustment instructions: Correction of effect with static pressure

- The system in which the FHBN is installed must be filled and exposed to the usual static pressure.
- A differential pressure must not be active, i.e. no pump operation and no flow.
- Remove the plastic cover and check slide switches 3 + 4.
- The FHBN is supplied with the correct voltage and the output voltage is displayed.
- Loosen the spindle locking screw above the inspection window.
- Adjust setting spindle "1" with a screwdriver until the output signal is "0".
- Retighten the spindle with the spindle locking screw.

Type series F

Dimensioned drawings

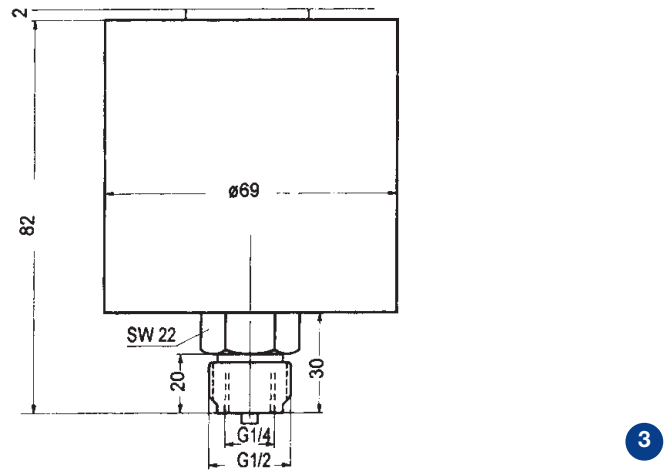
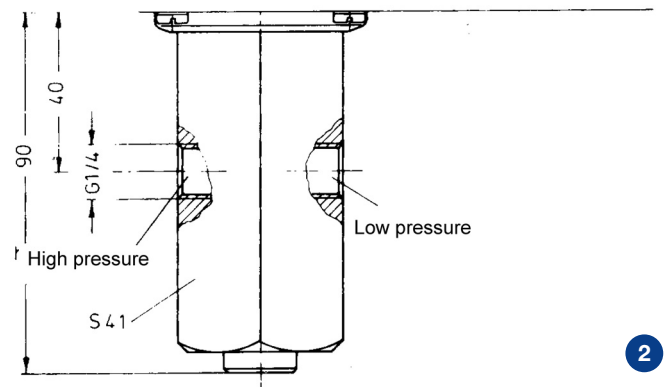
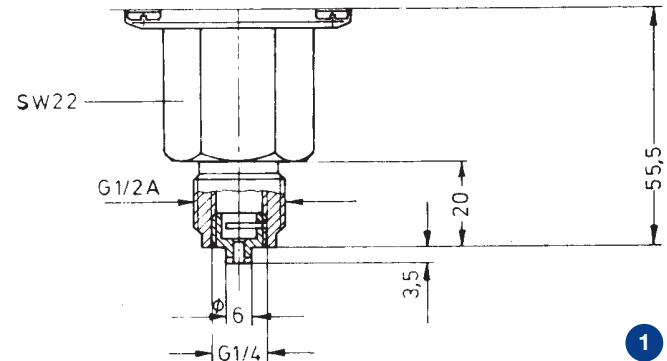
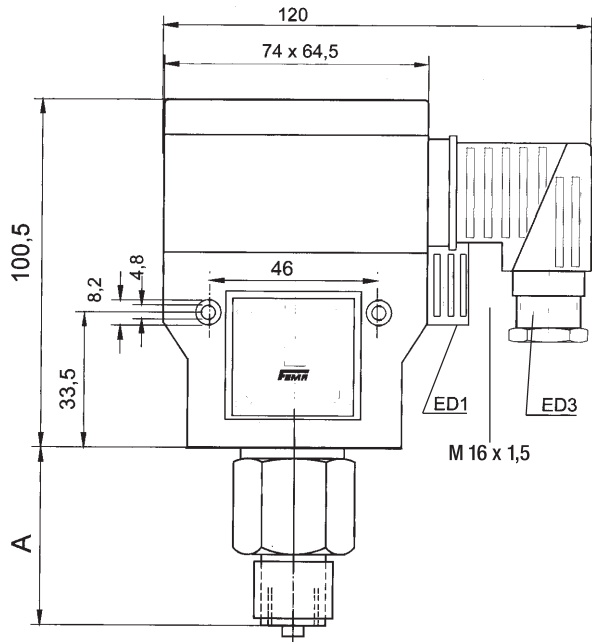

INSTRUMENT TEAM AS

Tlf: 67150 250 Faks: 67 150 251

Mail: post@instrumentteam.no

Web: www.instrumentteam.no

Dimensioned drawing no.	Types	A
1	FN 025-FN 3 FVN...	55.5
2	FHBN...	90
3	FN 505, FN 510	82

Height of evaluation module = 1 Module height = 34 mm.

The dimensions are for the basic device, consisting of sensor and evaluation module.

Each further plug-in module increases the overall height by one module unit = 34 mm.