

All stainless steel pressure gauges for special safety to DIN EN 837-1 with or without glycerine filling

Nominal size ND 100 and 160

Accuracy class 1.0

according to DIN EN 837-1 (DIN 16006)

Features

Solid front between measuring system and dial
Fulfills highest safety requirements to DIN 16006
Vibration free display and long service life
through glycerine filling
Ideal for hard conditions
High reliability on a longterm basis



Application

Chemical and petrochemical industry
Foodstoffs and beverages industry
Paper industry
Processing technology,
Machine and apparatus construction,

	with glycerine filling			
Models and ND	MR-36 100	MR-36 160	MR-36 100 F	MR-36 160 F
Connection	bottom			
Ranges in bar	0...0,6, 1, 1,6, 2,5, 4, 6, 10, 16, 25, 40, 60, 100, 160, 250, 400, 600, 1.000, 1.600 -0,6 / 0, -1 / 0, -1 / +0,6, -1 / +1,5, -1 / +3, -1 / +5, -1 / +9, -1 / +15, -1 / +24			
Application	Constant load : up to end of scale value Alternating load : up to 0,9 x end of scale value Short time : overload capacity 1,3 x			
Case	CrNi steel with blow - out back , solid front			
Bezel	CrNi steel bayonet ring			
Window	Lamineted safety glass			
Dial	Aluminium white, scale and imprint black			
Pointer	Aluminium ,black			
Movement	CrNi steel			
Maesuring element	CrNi steel Bourdon tube < 40 bar, helial tube > 60 bar			
Pressure Connection	SW 22, CrNi steel			
Connectionthread	G 1/2 B			
Protection	IP 65 to EN 60529 / IEC 529			
Temperatures	Medium: -20°C to 80°C, ambient: -25°C to 60°C			
Weight	0,6 kg	1,0 kg	1,6 kg	3,0 kg

Dimensions

Connection bottom

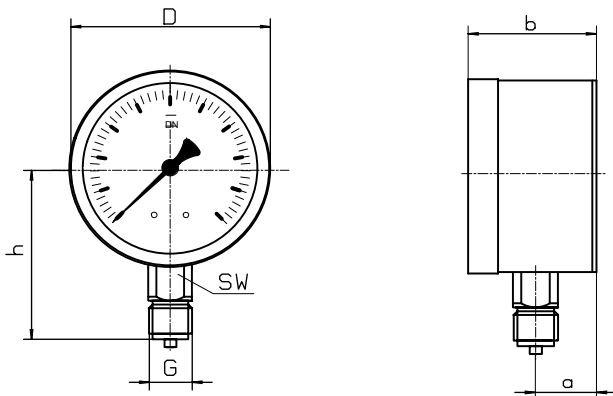

Front flange

Front flange

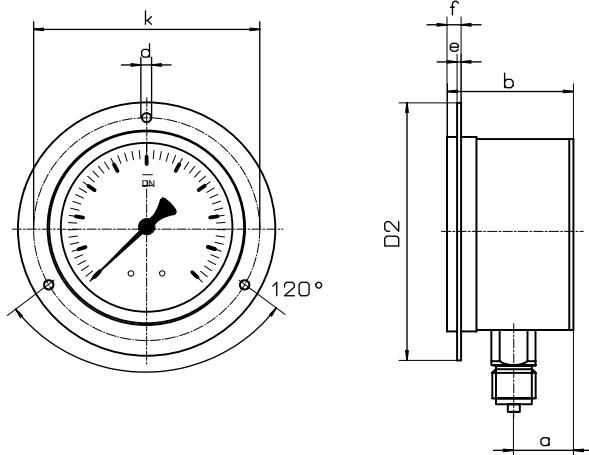

Dimensions in mm														
Model	NG	D	a	b		h		D2	e	f	k	d	sw	G
MR-36	100	101	27	60		86		132	2	6	116	5	22	G 1/2 B
MR-36	160	160	34	69		118		195	3	8	178	5,6	22	G 1/2 B

Modelspecification

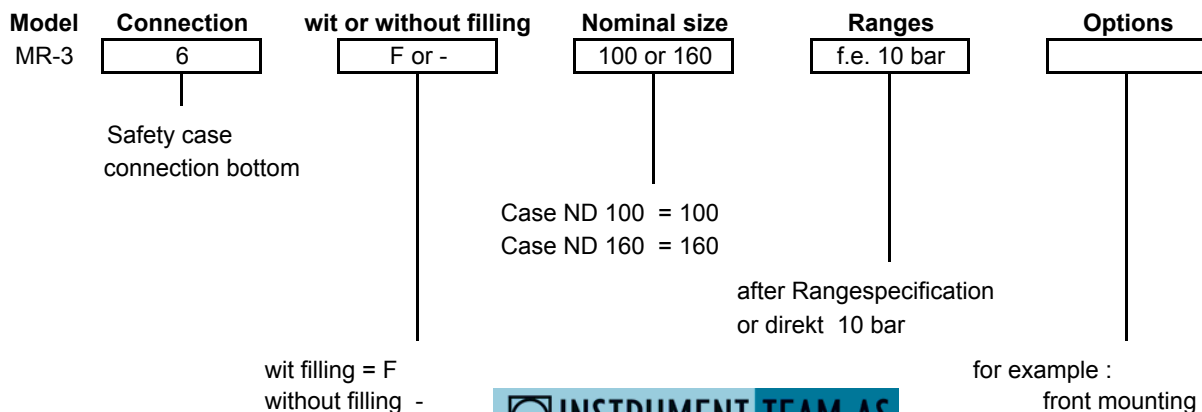

INSTRUMENT TEAM AS

Tlf: 67150 250 Faks: 67 150 251

Mail: post@instrumentteam.no

Web: www.instrumentteam.no