

## Smart Press

# PST... and PST...-R

## ELECTRONIC PRESSURE SWITCHES

### PRODUCT DATA



## APPLICATION

Honeywell FEMA's PST and PST...-R series Electronic Pressure Switches require adjustment (configuration and parameterization) in only two modes (the basic mode and the expert mode) and are suitable for an extremely wide range of applications, including the precision-adjustment and monitoring of system pressures in the field of plant construction, fluidics, process technology, and pneumatics, as well as in the monitoring and control of pumps and compressors.

Due to their monitored sensors with a standardized warning output, these devices are suitable for use in manufacturing lines in the automotive industry as well as in the area of machine tool construction. These switches provide sufficient accuracy (0.5% of final value) for measurement monitoring in many laboratory applications.

## FEATURES

<b>Housing and back</b>	polybutylene terephthalate (PBT)
<b>Max. ambient temp.</b>	-20...+60 °C
<b>Storage temperature</b>	-35...+80 °C
<b>Temperature, medium</b>	-20...+100 °C
<b>Relative air humidity</b>	0...95%, non-condensing
<b>Accuracy, total</b>	0.5% of final value
<b>Medium temp. drift</b>	0.3% per 10 K (0.5% per 10 K in case of 250/400/600 mbar)
<b>Total weight</b>	380 grams
<b>Parts in contact with medium</b>	
High-pressure versions	1.4571 + 1.4542
Low-pressure / flush	1.4571 + 1.4435
<b>Process connection</b>	
Manometer connection	G1/2" external thread
Flush connection	G3/4" external thread
<b>Electrical connection</b>	
PST series	5-prong M12 plug, A-coded as per DIN IEC 60947-5-2
PST...-R series	Extra 3-prong M12 plug
Protection class	II as per EN 60335-1
Protection type	IP65 as per EN 60529
Climate class	C as per DIN IEC 60654
Power supply	15...36 Vdc, max. 100 mA
EMC	compatible as per EN61326/A1
<b>Switch outputs (all versions)</b>	
Open-Collector outputs	Two; configurable as high-side/low-side or as push-pull switches, max. load: 250 mA / 15...36 Vdc
Reaction time	30 ms
Switching difference	(SP and RP) configurable
<b>Relay outputs (PST...-R series)</b>	
Contact type	1 switch-over contact
Min. electrical lifetime	250,000 switching cycles
<b>Switching performance, gold contacts (AgSnO<sub>2</sub>+Au)</b>	
AC1 (resistive)	1.5 VA (24 Vdc / 60 mA, 230 Vac / 6.5 mA)
AC15 (inductive)	unsuitable
Max. switch-on current	60 mA for < 5 ms
Min. switching perf.	50 mW (either > 5 V or > 2 mA)
<b>Switching performance, silver contacts (AgSnO<sub>2</sub>)</b>	
AC1 (resistive)	690 VA (230 Vac / 3 A)
AC15 (inductive)	230 VA (230 Vac / 1 A)
Max. switch-on current	30 A for < 5 ms
Min. switching perf.	500 mW (> 12 V or > 10 mA)
<b>Diagnostic output</b>	
Output configuration	warning output (plug 2), max. 20 mA, 15...36 Vdc
<b>Transmitter output (analog output)</b>	
Voltage / current	0...10 V and 4...20 mA, configurable in expert mode
Transient response	approx. 300 ms

## VARIANTS

The electronic pressure switches are available in two variants, easily distinguishable by the number of M12 plugs present on the rear side.

### PST... Series

The devices of this series provide both switching functionality and transmitting functionality.

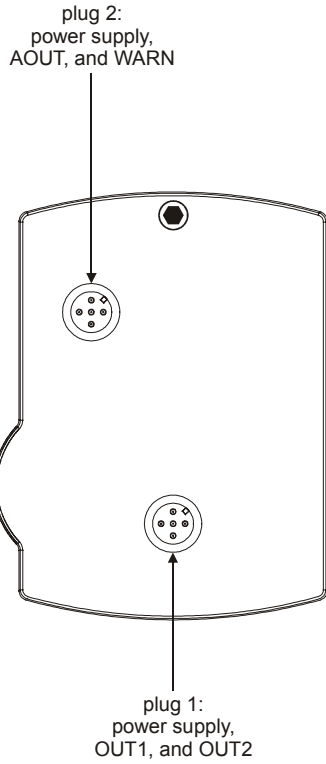

Fig. 1. PST... Series, rear view of housing

### PST...-R Series

Like PST... Series devices, the devices of this series provide switching and transmitting functionality, but also relaying functionality.

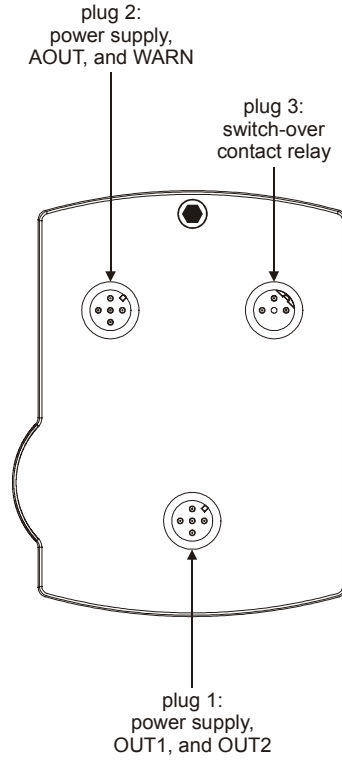

Fig. 2. PST...-R Series, rear view of housing

## FUNCTION

The PST and PST...R Electronic Pressure Switches are screwed directly into the pressure line or the boiler's connection nozzle. When monitoring gaseous media and high-viscosity liquids, G1/2" standard manometer can be used. In the case of low-viscosity and roiled liquids, G3/4" (flush) process connections must be used.

The LCD display screen indicates the pressure as a 4-digit digital value and as an analog value (bar graph).

Two LED's provide information on the switching status of the outputs and on the alarm status.

The device is configured and parameterized using the large rotary/push button. The user can move from screen to screen and enter values and/or change configurations by rotating the button. Values and configurations are confirmed and/or stored by pressing this button.

Parameterization and configuration are performed in only two modes (the basic mode and the expert mode).

### Basic Mode (Parameterization)

- Outputs 1 and 2: Adjustment of the switch-points (SP) and reverse switch-points (RP).
- Adjustment of the lower (ZERO) and upper (FSO = "full-scale output") reference values for limiting the analog output signal to a defined pressure range.
- Setting of a filter value in a range of 0...95% (ATT).
- When locked, can be unlocked by entering a CODE.

### Expert Mode (Configuration)

#### Output 1 (OUT1)

- Configurable as a maximum or minimum monitor.
- Configurable as a window monitor.
- Configurable as normally-open or normally-closed.
- Configurable as low-side/high-side switch or as push-pull switch.

#### Output 2 (OUT2)

- Configurable as a maximum or minimum monitor.
- Configurable as a window monitor.
- Configurable as normally-open or normally-closed.
- Configurable as low-side/high-side switch or as push-pull switch.
- Configurable as a warning output (max. 250 mA).

#### Analog Output (AOUT)

- Configurable as a 0...10 V / 10...0 V or 4...20 mA / 20...4 mA output (default setting: 0...10 V)

#### Additional Configuration

- Relay output (REL) configurable to be coupled with OUT1, OUT2, or the warning output.
- Selection of the pressure units (bar, Pa, or psi) in the UNIT display.
- Data restorable using the REST command.
- Selection of a 4-digit locking code (0001 to 9999) in the CODE display (0000 = no code).
- Simulation mode:
  - Using the rotary/push button, the pressure can be simulated over the entire range ("SIM1" shown in display).
  - The outputs can switch alternately ("SIM2" shown in display) in order to test the installation's reaction time in the range of from 4 times per second to once every 16 seconds (corresponding to a range of 0...100%).
- The LCD display's backlighting can be switched from "on continuously" ("LCD+" shown in display) to "turned off when rotary/push button not operated for 30 sec" ("LCD-" shown in display).
- Electronic drag indicator (represented in the LCD display by a dotted arrow) for indicating the max./min. pressure. After pressing the rotary/push button, the user can (in the EDIT mode) read off the elapsed time (in hours; resolution: 0.01 h) between the event and the present time.

## PROCESS CONNECTIONS

The device is connected to the pressure-side via a G1/2" standard manometer threaded connection or a G3/4" flush process connection (see fig. below). The geometry of the G1/2" and G3/4" connections conforms to DIN EN 837.

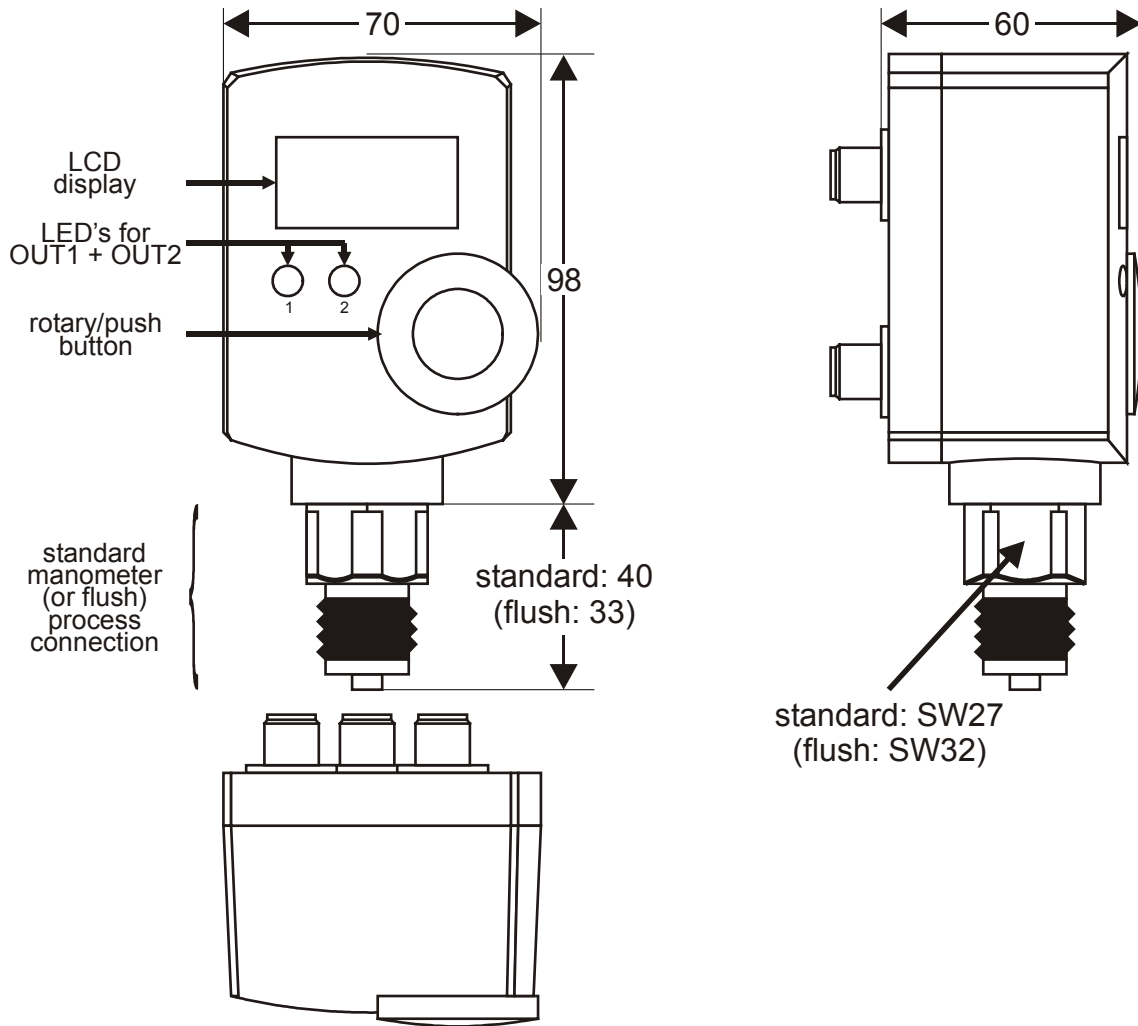

## PRODUCT IDENTIFICATION SYSTEM

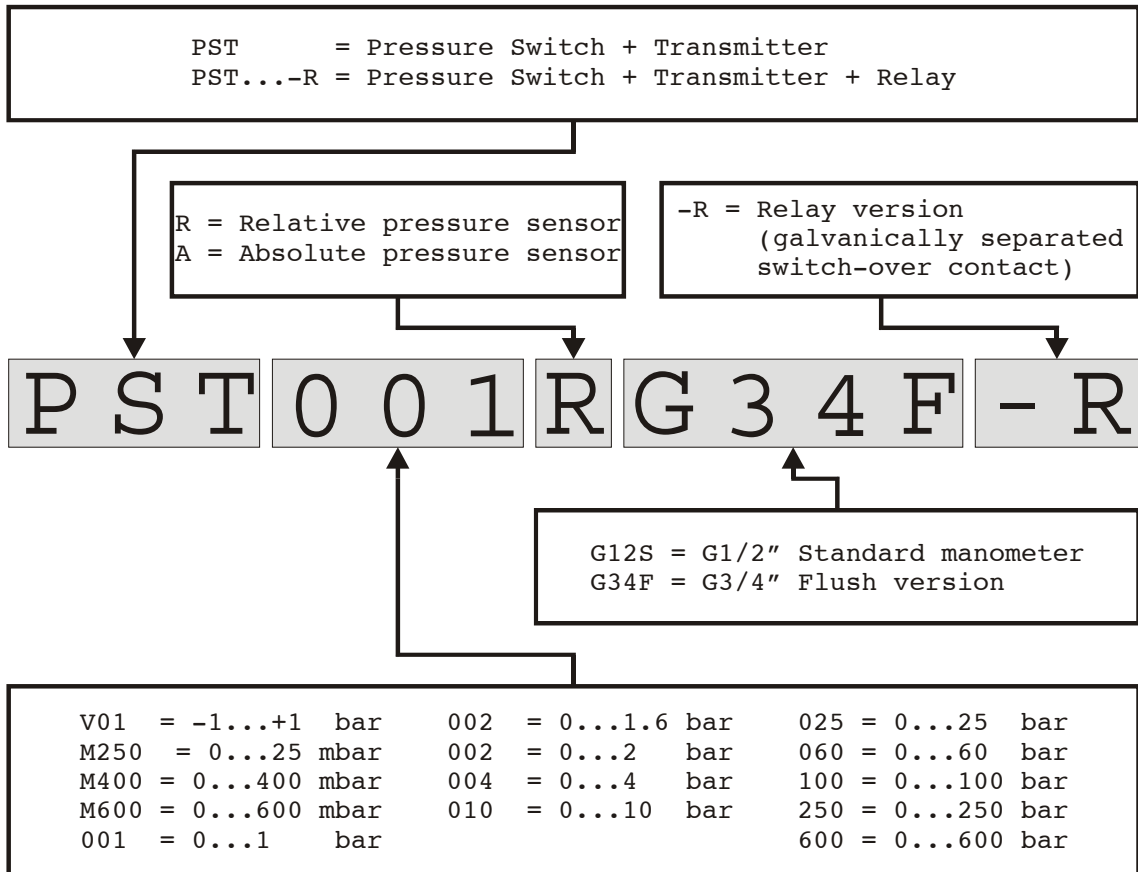

## PRESSURE RANGES

Table 1. Pressure ranges, connection, and equipment of models

pressure range (bar)	type of pressure	bursting pressure (bar)	max. pressure (bar)	temperature drift (%/10 K)	process connection	equipment	
						switch and transmitter	switch, transmitter, and relay
-1...+1	relative	≥ 10	6	0.3	G1/2"	PSTV01RG12S	PSTV01RG12S-R
0...0.25	relative	≥ 10	1	0.5*	G1/2"	PSTM250RG12S	PSTM250RG12S-R
0...0.4	relative	≥ 10	2	0.5*	G1/2"	PSTM400RG12S	PSTM400RG12S-R
0...0.6	relative	≥ 10	2	0.5*	G1/2"	PSTM600RG12S	PSTM600RG12S-R
0...1	relative	≥ 10	6	0.3	G1/2"	PST001RG12S	PST001RG12S-R
0...1.6	relative	≥ 10	6	0.3	G1/2"	PST002RG12S	PST002RG12S-R
0...4	relative	≥ 20	12	0.3	G1/2"	PST004RG12S	PST004RG12S-R
0...10	relative	≥ 50	30	0.3	G1/2"	PST010RG12S	PST010RG12S-R
0...25	relative	≥ 125	75	0.3	G1/2"	PST025RG12S	PST025RG12S-R
0...60	relative	≥ 300	180	0.3	G1/2"	PST060RG12S	PST060RG12S-R
0...100	relative	≥ 500	300	0.3	G1/2"	PST100RG12S	PST100RG12S-R
0...250	relative	≥ 1600	500	0.3	G1/2"	PST250RG12S	PST250RG12S-R
0...600	relative	≥ 1800	1000	0.3	G1/2"	PST600RG12S	PST600RG12S-R
-1...+1	relative	≥ 10	6	0.3	G3/4"	PSTV01RG34F	PSTV01RG34F-R
0...0.25	relative	≥ 10	1	0.5*	G3/4"	PSTM250RG34F	PSTM250RG34F-R
0...0.4	relative	≥ 10	2	0.5*	G3/4"	PSTM400RG34F	PSTM400RG34F-R
0...0.6	relative	≥ 10	2	0.5*	G3/4"	PSTM600RG34F	PSTM600RG34F-R
0...1	relative	≥ 10	6	0.3	G3/4"	PST001RG34F	PST001RG34F-R
0...1.6	relative	≥ 10	6	0.3	G3/4"	PST002RG34F	PST002RG34F-R
0...4	relative	≥ 20	12	0.3	G3/4"	PST004RG34F	PST004RG34F-R
0...10	relative	≥ 50	30	0.3	G3/4"	PST010RG34F	PST010RG34F-R
0...25	relative	≥ 125	75	0.3	G3/4"	PST025RG34F	PST025RG34F-R
0...2	absolute	≥ 10	6	0.3	G1/2"	PST002AG12S	PST002AG12S-R
0...10	absolute	≥ 50	30	0.3	G1/2"	PST010AG12S	PST010AG12S-R
0...2	absolute	≥ 10	6	0.3	G3/4"	PST002AG34F	PST002AG34F-R
0...10	absolute	≥ 50	30	0.3	G3/4"	PST010AG34F	PST010AG34F-R

**NOTE\*:** Due to their design, depending upon their installation orientation, the weight of the diaphragm and of the filling medium in the sensors of the PSTM... series can have an effect on measurement values of up to 0.5% FS. The devices are all calibrated in the vertical position; in other orientations, deviations in measurement values are therefore possible. For this reason, vertical installation (i.e. with the device positioned vertically above the connection pipe) is to be preferred. In the event that devices of the PSTM... series are installed in a horizontal position, they can be zeroed using the integrated zeroing function ("SET0" shown in the display) prior to initial operation.



