

## TST... and TST...-R ELECTRONIC THERMOSTATS

### PRODUCT DATA



### APPLICATION

Honeywell FEMA's TST and TST...R series thermostats require adjustment (configuration and parameterization) in only two modes (the basic mode and the expert mode) and are suitable for the precision-adjustment and monitoring of medium temperatures in the fields of plant construction, fluidics, process technology, and pneumatics, as well as in the monitoring and control of furnaces, heating units, and process temperatures, as well as for applications in the field of frost protection.

These thermostats provide sufficient accuracy (0.5% of the final value) for measurement monitoring in many laboratory applications. Models with built-on sensors for a temperature range of -50...+200 °C and models with an external sensor for a temperature range of -50...+400 °C are available. Customized PT1000 precision class-A sensors can also be employed in the aforementioned temperature ranges.

### TECHNICAL DATA

<b>Housing and back</b>	polybutylene terephthalate (PBT-GK30), chemically and stress-crack resistant
<b>Display screen cover</b>	polycarbonate (PC)
<b>Max. ambient temp.</b>	-20...+60 °C
<b>Storage temperature</b>	-35...+80 °C
<b>Temperature, medium</b>	-50...+400 °C (depending on model)
<b>Relative air humidity</b>	0...95%, non-condensing
<b>Accuracy, total</b>	0.5% of final value
<b>Total weight</b>	depends on model
<b>Parts in contact with medium</b>	
Built-on sensors	1.4571
<b>Process connection</b>	
Standard built-on sensor	G1/2" external thread
External sensor	PT1000, class A
<b>Electrical connection</b>	
TST version	5-prong M12 plug, as per DIN IEC 60947-5-2
TST...-R version	Extra 3-prong M12 plug
<b>Protection class</b>	II as per EN 60335-1
<b>Protection type</b>	IP65 as per EN 60529
<b>Climate class</b>	C as per DIN IEC 60654
<b>Power supply</b>	14...36 Vdc (above 50 °C, max. 30 Vdc), max. 100 mA
<b>EMC</b>	as per EN 61326/A1
<b>Open-Collector outputs</b>	2; configurable as high-side/low-side or push-pull switches, max. load: 250 mA/14...36 Vdc
<b>Switching difference</b>	(SP and RP) configurable
<b>Relay outputs (TST...-R series)</b>	
AC1 (resistive)	250 Vac / 5 A
AC15 (inductive)	250 Vac / 0,8 A (200 VA)
Contact type	1 switch-over contact
Min. electrical lifetime	100,000 switching cycles
<b>Diagnostic output</b>	
Output configuration	warning output (plug 2), max. 20 mA, 14...36 Vdc
<b>Transmitter output (analog output)</b>	
Voltage / current	0...10 V and 4...20 mA, configurable in expert mode

## FUNCTION

The TST and TST...R Thermostats are screwed directly into the pressure line or the boiler's (medium container's) connection nozzle. Built-on or external PT1000 accuracy class-A sensors are used to monitor gaseous media and high-viscosity liquids. The sensor signal can be used for both single/two-channel switching functions (with freely-configurable switch-point and reverse switch-point) and analog signals (0...10 V and 4...20 mA).

As soon as the sensor is screwed into place and connected with the power supply, the LCD display screen indicates the temperature as a 4-digit digital value and as an analog value (bar graph).

Two LED's provide information on the switching status of the outputs and on the alarm status.

The thermostats are configured and parameterized using the large rotary/push button. The user can move from screen to screen and enter values and/or change configurations by rotating the button. Values and configurations are confirmed and/or stored by pressing this button.

Parameterization and configuration are performed in only two modes (the basic mode and the expert mode).

### Basic Mode (Parameterization)

- Outputs 1 and 2: Adjustment of the switch-points (SP) and reverse switch-points (RP).
- Switch ON/OFF delay of 0...3600 seconds.
- Adjustment of the lower (ZERO) and upper (FSO = "full-scale output") reference values for limiting the analog output signal to a defined temperature range.
- Setting of a filter value in a range of 0...95% (ATT).
- [When locked, can be unlocked by entering a CODE.](#)

### Expert Mode (Configuration)

#### Output 1 (OUT1)

- Configurable as a maximum or minimum monitor.
- Configurable as a window monitor.
- Configurable as normally-open or normally-closed.
- Configurable as low-side/high-side switch or as push-pull switch.

#### Output 2 (OUT2)

- Configurable as a maximum or minimum monitor.
- Configurable as a window monitor.
- Configurable as normally-open or normally-closed.
- Configurable as low-side/high-side switch or as push-pull switch.
- Configurable as a warning output (max. 250 mA).

#### Analog Output (AOUT)

- Configurable as a 0...10 V / 10...0 V or 4...20 mA / 20...4 mA output (default setting: 0...10 V)

#### Additional Configuration

- Relay output (REL) configurable to be coupled with OUT1, OUT2, or the warning output.

- Selection of the temperature units (°C or °F) in the UNIT display.
- Data restorable using the REST command.
- Selection of a 4-digit locking code (0001 to 9999) in the CODE display (0000 = no code).
- Simulation mode:
  - Using the rotary/push button, the temperature can be simulated over the entire range.
  - The outputs can (in part) switch alternately in order to test the installation's reaction time in the range of from 4 times per second to once every 16 seconds (corresponding to 0...100%).
- The LCD display's backlighting can be switched from "on continuously" ("LCD+" shown in display) to "turned off when rotary/push button not operated for 30 sec" ("LCD-" shown in display).
- Electronic drag indicator (represented in the LCD display by a dotted arrow) for indicating the max./min. temperature. After pressing the rotary/push button, the user can (in the EDIT mode) read off the elapsed time (in hours; resolution: 0.01 h) between the event and the present time.

### Process Connections

The device is connected to the temperature-side via a immersion sensor with a G1/2" threaded connection; in the case of external sensors, via an M8 plug (available as an accessory) on the device's sensor-side.

SmartTemp thermostats with a temperature range of -50...+50°C are equipped with built-on PT1000 class-A temperature sensors. Two different lengths are available (100 mm and 250 mm).

To improve their thermal insulation, the built-on sensors for a temperature range of -50...+200°C are designed as neck-tube sensors.

All sensors for a temperature range of -50...+400°C are designed as external sensors and are attached to the evaluation electronics using an M8 plug (available as an accessory).

A universal mounting kit is available as an accessory for screwing the device either directly to the wall or installing it to a C rail.

## MODELS AND TEMPERATURE RANGES

temperature range	sensor immersion depth (mm)	line length	switch / transmitter model	switch / transmitter / relay model
-50...+50 °C	100	built on	TST050G12100	TST050G12100-R
-50...+50 °C	250	built on	TST050G12250	TST050G12250-R
-50...+200 °C	100	built-on neck-tube	TST200G12100	TST200G12100-R
-50...+200 °C	250	built-on neck-tube	TST200G12250	TST200G12250-R
-50...+200 °C	n.a.	external, w/ cable*	TST200EPT1K	TST200EPT1K-R
-50...+400 °C	n.a.	external, w/ cable*	TST400EPT1K	TST400EPT1K-R

\* Sensors not included in delivery.

Using the TST400EPT1K, customized PT1000 class-A sensors can be evaluated in the aforementioned temperature ranges. PT1000 class-A sensors, only, may be used insofar as the required accuracy of 0.5% will otherwise not be maintained.

### External Sensors

temperature range	sensor immersion depth (mm)	line length	sensor design	model	remark
-50...+400 °C	100	2,5 m	external	P2-TVS12-400-100	plug included
-50...+400 °C	250	2,5 m	external	P2-TVS12-400-250	plug included

## ACCESSORIES

The following optional accessories are also available (must be ordered separately).

### Thermowells

Material: Stainless steel 1.4571 / 316L

model	A	B	C	D	E	F	screwing
G12-100	105	36	19	14	15	83	G 1/2" (cylindrical)
G12-250	255	36	19	14	15	233	G 1/2" (cylindrical)
R12-100	105	36	19	14	15	83	R 1/2" (conical)
R12-250	255	36	19	14	15	233	R 1/2" (conical)
N12-100	105	36	19	14	15	83	N 1/2" (conical NPT)
N12-250	255	36	19	14	15	233	N 1/2" (conical NPT)

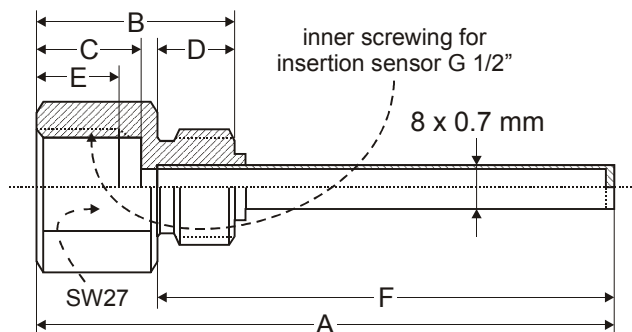

### M12 Couplings

For Plugs 1+2 (5-prong plug for power supply and switching/analog outputs)

ST12-5-G (straight design)

ST12-5-A (angled design)

For Plug 3 (3-prong relay output of TST....-R)

ST12-4-G (straight design)

ST12-4-A (angled design)

ST12-4-GK (straight design with 2 m cable)

ST12-4-AK (angled design with 2 m cable)

### Other Accessories

AST1 wall mounting kit (for mounting TST...E... for evaluating external sensors)

ST8-3 (3-prong M8 plug according to DIN IEC 60947-5-2, with screw terminals)

## DIMENSIONS

PT 1000 class-A sensors, with stainless steel thermowell (1.4571).

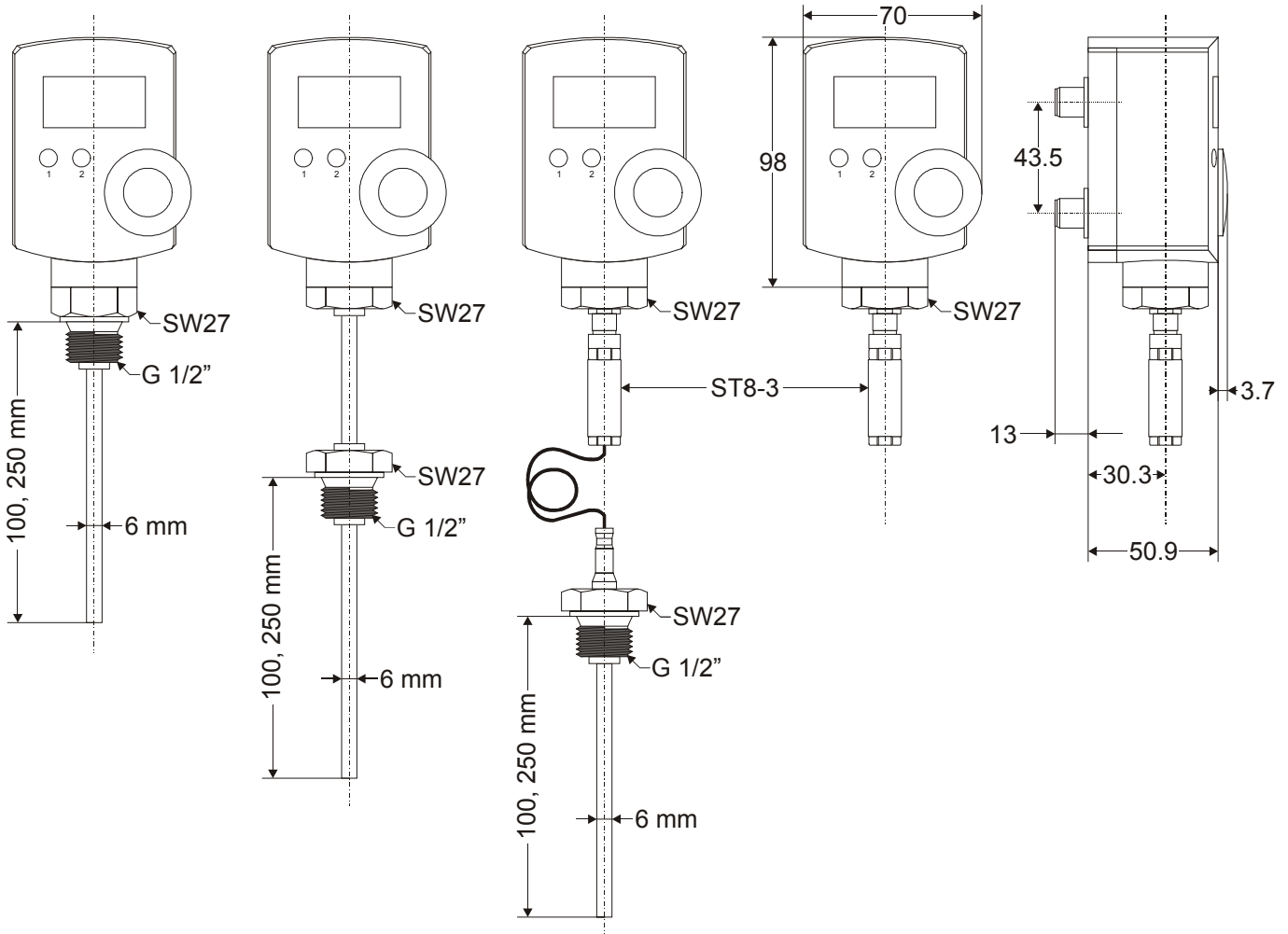

**Honeywell**



**INSTRUMENT TEAM AS**

Tlf: 67150 250 Faks: 67 150 251

Mail: [post@instrumentteam.no](mailto:post@instrumentteam.no)

Web: [www.instrumentteam.no](http://www.instrumentteam.no)

DIN EN  
ISO 9001